



DESIGN EXAMPLE REPORT

Title	<i>20 W Power Supply with Very Low No-load Power Consumption Using TOP255PN</i>
Specification	85 – 265 VAC Input; 12 V, 1.67 A Output
Application	Various
Author	Applications Engineering Department
Document number	DER-188
Date	September 30, 2008
Revision	1.0

Summary and Features

- Very low no-load consumption: <100 mW at 230 VAC
- High active-on average efficiency: 85% / 86% at 115 VAC / 230 VAC
 - Exceeds ENERGY STAR 2.0 efficiency requirement of 81%
- High available standby output power at 115 VAC / 230 VAC:
 - 0.75 W at 1.0 W input power
 - 0.35 W at 0.5 W input power
 - 0.2 W at 0.3 W input power
- Line sensing
 - Line feed-forward for excellent line ripple rejection
 - Intelligent brown-out protection (undervoltage lockout (UVLO), with auto-restart)
 - Extended line surge immunity (overvoltage shutdown)
- No heat sink necessary, by design
- Hysteretic thermal over load and output short-circuit protection

PATENT INFORMATION

The products and applications illustrated herein (including transformer construction and circuits external to the products) may be covered by one or more U.S. and foreign patents, or potentially by pending U.S. and foreign patent applications assigned to Power Integrations. A complete list of Power Integrations' patents may be found at www.powerint.com. Power Integrations grants its customers a license under certain patent rights as set forth at <http://www.powerint.com/ip.htm>.

Table of Contents

1	Introduction.....	3
2	Scope	4
3	Power Supply Specification	5
4	Schematic.....	6
5	Circuit Description	7
5.1	TOP255PN Operation	7
5.2	Input Filtering.....	7
5.3	TOP255PN Primary.....	7
5.4	TOP255PN Secondary.....	9
5.5	Output Rectification and Filtering	9
6	PCB Layout	10
7	Bill of Materials	11
8	Transformer Details.....	12
8.1	Electrical and Mechanical Diagram	12
8.2	Electrical Specifications.....	12
8.3	Materials.....	12
8.4	Build Diagram.....	13
8.5	Transformer Construction.....	13
9	Design Spreadsheet.....	14
10	Power Supply Performance	18
10.1	Energy Efficiency.....	18
10.2	Output Regulation and Quality	21
10.3	Transient Load	24
10.4	Startup.....	25
11	Conducted EMI	26
11.1	Waveform Plots	27
12	Revision History	29

Important Note:

Although this board is designed to satisfy safety isolation requirements, the engineering prototype has not been agency approved. Therefore, all testing should be performed using an isolation transformer to provide the AC input to the prototype board.



1 Introduction

This engineering report describes a generic universal input, 12 V, 20 W output power supply employing the Power Integrations® TOPSwitch®-HX integrated off-line switcher TOP255PN. This power supply provides very low no-load power consumption and excellent standby efficiency.

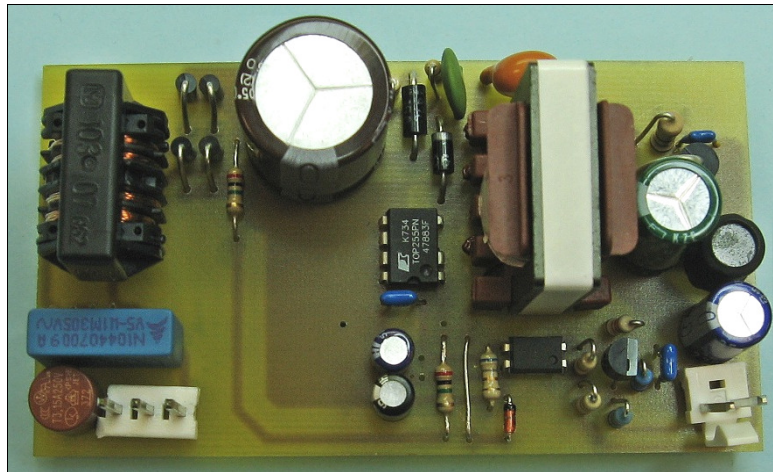

Figure 1 – Populated Circuit Board Photograph.

This document contains the specifications, schematic, bill of materials, transformer construction details, and performance data for designing this power supply. This document also includes design considerations specific to addressing low no-load power consumption.

2 Scope

This report focuses on energy efficiency with special considerations given to the no-load input power consumption of this design. Performance test data is contained in this report with the exception of thermal tests. The conducted EMI test results suggest radiated EMI would be passed without significant additional work.

The following calibrated test equipment was used in gathering data for this report:

- Power meter Yokogawa WT210
- Programmable AC source Chroma model # 61502
- Programmable DC load Chroma model # 6314/63103
- Digital Storage Oscilloscope Yokogawa DL1740
- Current probe Tektronix A6302 and current probe amplifier Tektronix AM503
- Voltage probe 10:1 Tektronix P6105A
- DMM Fluke 87
- EMI test receiver Rhode & Schwarz ESPC
- Two-line V-Network Rhode & Schwarz ESH 3-Z5



3 Power Supply Specification

Description	Min.	Typ.	Max.	Peak	Unit	Notes
Input						
Voltage	85	115/230	265		VAC	2 wire input
Frequency	47	50	63		Hz	
Output						
Output Voltage	11.4	12.0	12.6		V	±5% 1%, 20 MHz bandwidth
Output Voltage Ripple			120		mVpp	
Output Current	0		1.67		A	
Total Output Power	0		20		W	
Energy Efficiency						
Full load efficiency	81%	84%				Measured at 20 W, +25 °C 25%, 50%, 75%, 100% at 115/230 VAC per ENERGY STAR 2.0 (March 6, 2008) At 1.0 W input power At 0.50 W input power At 0.30 W input power At 230 VAC
Average active-on	81%	84%				
Standby output power	0.70	0.75			W	
	0.30	0.35			W	
No-load consumption	0.15	0.20			W	
		0.08	0.1		W	
Environmental						
Conducted EMI Safety	Meets EN 55022 Class B Designed to meet EN 60950, Class II					
Ambient Temperature	0		+50		°C	Free convection, sea level

Table 1 – Power Supply Specification.



5 Circuit Description

This design centers around the TOP255PN in a flyback topology for a very low no-load power supply operating from universal inputs and providing a 12 V, 20 W output.

5.1 TOP255PN Operation

The TOP255PN (U1) converts a current at the CONTROL pin to a duty cycle at the open drain output of its integrated, high-power MOSFET. IC U1 also provides high-voltage start-up, cycle-by-cycle current limiting, loop compensation circuitry, and auto-restart and thermal shutdown. The high-voltage (700 V) MOSFET and all low-voltage control circuitry are cost-effectively integrated onto a single monolithic IC.

IC U1 uses the Multi-function (M) pin to combine the features normally requiring several pins onto one. The M pin acts as the single input for line overvoltage (OV), line undervoltage (UV), line feed-forward with DC_{MAX} reduction, output overvoltage protection (OVP), external current-limit adjustment, remote ON/OFF, and device reset functions.

In this design only the UV, OV and DC_{MAX} reduction features are used, via R3 and R4.

During normal MOSFET operation, duty cycle decreases linearly with increasing C-pin current. See Figure 9 in the TOPSwitch-HX data sheet for details.

Capacitor C6 is the decoupling capacitor for U1. Capacitor C5 both sets the auto-restart timing and, with R6, provides control loop compensation.

5.2 Input Filtering

Fuse F1 provides catastrophic fault protection to the circuit, and isolates it from the AC source. X-capacitor C1 reduces differential-mode EMI. Y-capacitor C7 (across the isolation barrier) and common-mode inductor L1 filter common-mode EMI. The value of C1 is sufficiently low to allow safe removal of the AC source without bleed resistors, in compliance with UL standard 60950-1. Diodes D1 through D4 rectify the AC input. Capacitor C2 filters the resulting DC.

5.3 TOP255PN Primary

A clamp network formed by VR1, R9, C3, R8, and D5 protects U1 from voltage spikes caused by leakage inductance on the transformer primary side at MOSFET turn off. Resistors R3 and R4 sense the DC bus voltage to provide line feed-forward information (for improved line ripple rejection), set the UVLO startup voltage threshold (intelligent brown-out protection), and provide extended line surge immunity via the OV shutdown feature.



The current fed from the DC bus into U1's M pin is proportional to the DC voltage across capacitor C2. When this voltage reaches approximately 95 V DC, the current through this resistor becomes greater than 25 μ A. This causes the line under-voltage threshold to be exceeded, enabling U1. Resistors R3 and R4 are rated for ¼ W each to withstand the DC voltage expected across them.

The TOPSwitch HX regulates the output using PWM-based voltage-mode control. At high loads the controller operates at full switching frequency (66 kHz for this design). Changes in the CONTROL pin current cause changes to the duty cycle. This regulates the output voltage.

The internal current limit provides cycle-by-cycle peak current limit protection. The integrated controller has a second current limit comparator for monitoring the actual peak drain current (I_P) relative to the programmed current limit $I_{LIMITEXT}$. When the ratio $I_P/I_{LIMITEXT}$ falls below 55%, the peak drain current is held constant and the TOPSwitch operates in a fixed duty cycle variable frequency mode (variable frequency PWM control mode). As the load continues to decrease, the switching frequency also decreases linearly down to 30 kHz.

Once the switching frequency drops to 30 kHz, the controller keeps it constant and reduces the peak current to regulate the output (reverting to a fixed frequency, direct duty-cycle PWM control mode).

As the load continues to decrease and the ratio $I_P/I_{LIMITEXT}$ reaches 25%, the controller enters multi-cycle-modulation mode. This mode offers excellent efficiency under light-load conditions (such as in standby operation), and low no-load input power consumption.

Using a fast-recovery (rather than an ultra-fast) diode for D5 allows some of the clamp energy to be recovered. This improves efficiency at light loads and reduces the no-load consumption of the power supply. Resistor R8 limits reverse diode current and dampens high-frequency ringing. Zener diode VR1 reduces no-load dissipation effectively disconnecting R9 when the voltage across C3 falls below 150 V.

The bias winding of transformer T1 bias winding is designed such that during no-load the bias voltage supplying optocoupler U5 drops to approximately 8.5 V. This reduces the power drawn from the bias winding to supply U1 and moves its operation into multi-cycle-modulation mode during this load condition. As a consequence the power supply no-load consumption is reduced and the standby efficiency is increased.

The output of the bias winding is rectified by diode D6 and filtered by capacitor C4. Optocoupler U5 supplies the control and supply current directly to the CONTROL (C) pin of U1.



The power supply's output voltage is regulated by the feedback circuit on the secondary side, which controls the output voltage by changing the optocoupler current. A change in the optocoupler current causes a change in current flowing into the CONTROL pin. Variation of the current into the C pin results in a variation of the duty cycle, which changes the power supply's output voltage.

5.4 TOP255PN Secondary

Optocoupler U5 supplies the necessary IC supply and feedback current to the CONTROL pin. Using a high-gain optocoupler, such as the PC817D, with a CTR of 300% to 600% reduces secondary side dissipation. A high CTR also allows a higher value for R11, which reduces no-load input power even further (by approximately 30 mW) at 265 VAC.

Reference IC (shunt regulator) U4 has a 400 μ A typical minimum cathode current requirement for correct operation which is provided via R12. Resistors R15 and R16 form a voltage divider which is used to sense the output. Resistor R13 and capacitor C10 are compensation elements around U4 which set the feedback circuit frequency response. Resistor R11 sets the overall DC loop gain and limits the current through U5 during transient state conditions.

5.5 Output Rectification and Filtering

A snubber network on the output formed by R14 and C11 attenuates high-frequency ringing for reduced EMI. These two components were chosen with smaller values to allow high-frequency ringing to be damped while keeping any power dissipation they cause at no-load to a minimum. Inductor L2 and capacitor C9 form an output second-stage filter.



6 PCB Layout

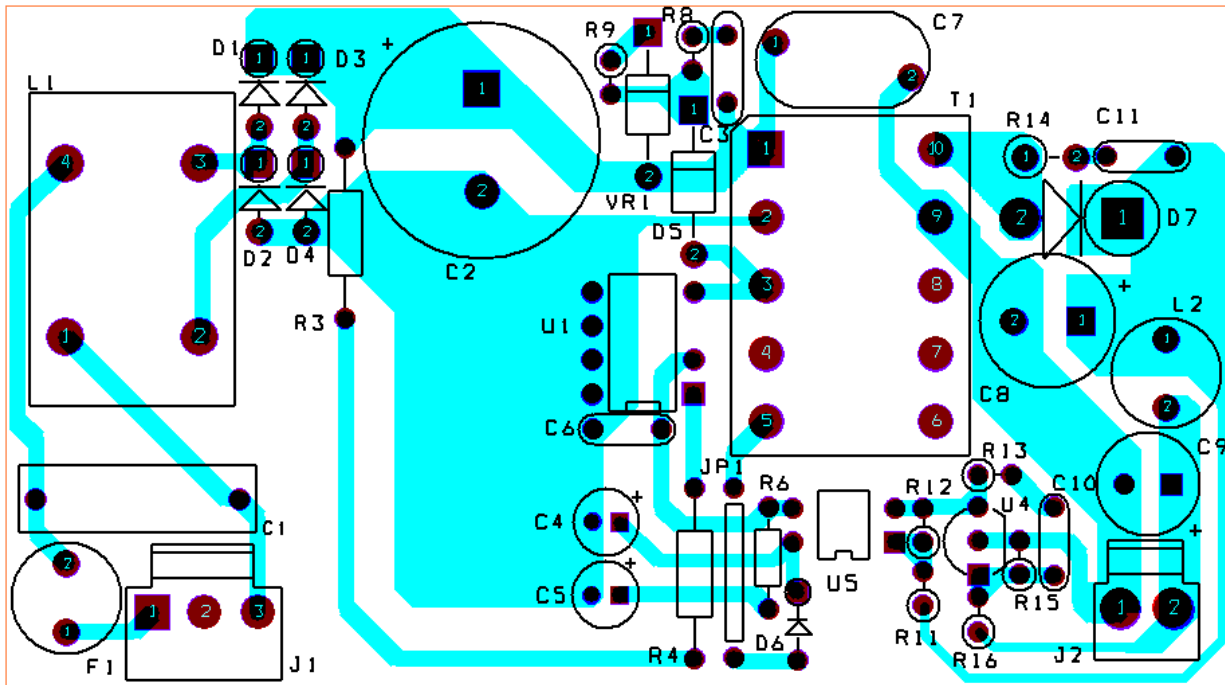

Figure 3 – Printed Circuit Board Layout.



7 Bill of Materials

Item	Qty	Ref Des	Description	Mfg Part Number	Mfg
1	1	C1	100 nF, 275 VAC, Film, X2	ECQ-U2A104ML	Panasonic
2	1	C2	47 μ F, 400 V, Electrolytic, Low ESR, 750 m Ω , (18 x 20)	EKMX401ELL470MM20S	Nippon Chemi-Con
3	1	C3	2.2 nF, 1 kV, Disc Ceramic	NCD222K1KVY5FF	NIC Components Corp
4	1	C4	10 μ F, 50 V, Electrolytic, Gen. Purpose, (5 x 11)	KME50VB10RM5X11LL	Nippon Chemi-Con
5	1	C5	47 μ F, 35 V, Electrolytic, Gen. Purpose, (5 x 11)	EKMG350ELL470ME11D	Nippon Chemi-Con
6	2	C6 C10	100 nF, 50 V, Ceramic, X7R	B37987F5104K000	Epcos
7	1	C7	1 nF, Ceramic, Y1	440LD10-R	Vishay
8	1	C8	680 μ F, 25 V, Electrolytic, Very Low ESR, 23 m Ω , (10 x 20)	EKZE250ELL681MJ20S	Nippon Chemi-Con
9	1	C9	220 μ F, 25 V, Electrolytic, Very Low ESR, 72 m Ω , (8 x 11.5)	EKZE250ELL221MHB5D	Nippon Chemi-Con
10	1	C11	1 nF, 100 V, Ceramic, COG	B37979G1102J000	Epcos
11	4	D1 D2 D3 D4	1000 V, 1 A, Rectifier, DO-41	1N4007-E3/54	Vishay
12	1	D5	800 V, 1 A, Fast Recovery Diode, 500 ns, DO-41	FR106	Diodes Inc.
13	1	D6	75 V, 300 mA, Fast Switching, DO-35	1N4148	Vishay
14	1	D7	100 V, 5 A, Schottky, DO-201AD1	SB5100	Fairchild
15	1	F1	3.15 A, 250V, Fast, TR5	37013150410	Wickman
16	1	J1	3 Position (1 x 3) header, 0.156 pitch, Vertical	26-48-1031	Molex
17	1	J2	2 Position (1 x 2) header, 0.156 pitch, Vertical, Straight-Friction Lock Header	26-48-1025	Molex
18	1	JP1	Wire Jumper, Insulated, 22 AWG, 0.5 in	C2004-12-02	Gen Cable
19	1	L1	10 mH, 0.7 A, Common Mode Choke	ELF15N007A	Panasonic
20	1	L2	3.3 μ H, 5.5 A, 8.5 x 11 mm	R622LY-3R3M	Toko
21	2	R3 R4	2.0 M Ω , 5%, 1/4 W, Carbon Film	CFR-25JB-2M0	Yageo
22	1	R6	6.8 Ω , 5%, 1/8 W, Carbon Film	CFR-12JB-6R8	Yageo
23	1	R8	22 Ω , 5%, 1/4 W, Carbon Film	CFR-25JB-22R	Yageo
24	1	R9	2.7 k Ω , 5%, 1/4 W, Carbon Film	CFR-25JB-2K7	Yageo
25	1	R11	1 k Ω , 1%, 1/4 W, Metal Film	MFR-25FBF-1K00	Yageo
26	1	R12	2 k Ω , 5%, 1/4 W, Carbon Film	CFR-25JB-2K0	Yageo
27	1	R13	2.2 k Ω , 5%, 1/4 W, Carbon Film	CFR-25JB-2K2	Yageo
28	1	R14	10 Ω , 5%, 1/2 W, Carbon Film	CFR-50JB-10R	Yageo
29	1	R15	10 k Ω , 1%, 1/4 W, Metal Film	ERO-S2PHF1002	Panasonic
30	1	R16	38.3 k Ω , 1%, 1/4 W, Metal Film	MFR-25FBF-38K3	Yageo
31	1	T1	Bobbin, EF25/13/7, Vertical, 10 pins	FE0106	Miles-Platt
32	1	U1	TOPSwitch-HX, TOP255PN, DIP-8C	TOP255PN	Power Integrations
33	1	U4	2.495 V Shunt Regulator IC, 2%, 0 to 70C, TO-92	TL431CLPG	On Semiconductor
34	1	U5	Opto coupler, 35 V, CTR 300-600%, 4-DIP	PC817X4	Sharp
35	1	VR1	150 V, 1.5 W, DO-41	BZY97C150	Fagor



8 Transformer Details

8.1 Electrical and Mechanical Diagram

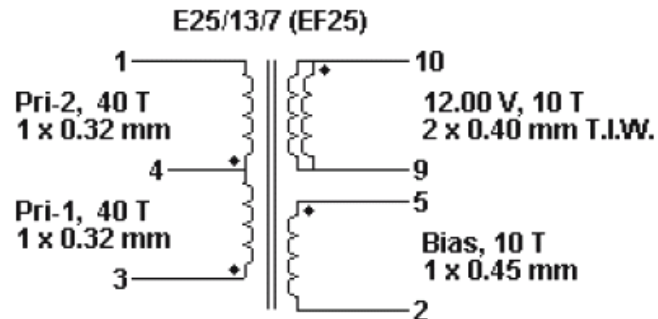

8.2 Electrical Specifications

Electrical Strength	1 second, 60 Hz, from Primary to Secondary	3000 VAC
Primary Inductance	Pins 1 - 3, all other windings open, measured at 66 kHz, 0.4 VRMS	1.56 mH, ±5%
Resonant Frequency	Pins 1 - 3, all other windings open	1500 kHz (Min.)
Primary Leakage Inductance	Pins 1 - 3, with Pins 10 and 9 shorted, measured at 66 kHz, 0.4 VRMS	14 μH (Max.)

8.3 Materials

Item	Description
[1]	Core: EF25, NC-2H or Equivalent, gapped for ALG of 244 nH/t ²
[2]	Bobbin: EF25, 5 pri. + 5 sec.
[3]	Barrier Tape: Polyester film 15.60 mm wide
[4]	Varnish
[5]	Magnet Wire: 0.32 mm, Solderable Double Coated
[6]	Magnet Wire: 0.45 mm, Solderable Double Coated
[7]	Triple Insulated Wire: 0.4 mm

8.4 Build Diagram

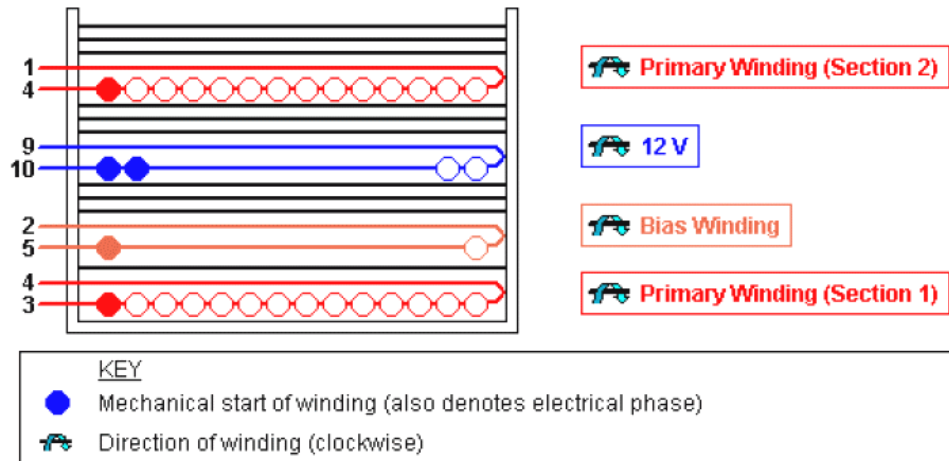

Figure 5 – Transformer Mechanical Drawing.

8.5 Transformer Construction

WD #1 Primary Winding #1	Start on pin 3 and wind 40 turns (x 1 filar) of item [5] in 1 layer from left to right. On the final layer, spread the winding evenly across entire bobbin. Finish this winding on pin 4.
Insulation	Add 1 layer of tape, item [3], for insulation.
WD#2 Feedback/Bias	Start on pin 5 and wind 10 turns (x 1 filar) of item [6]. Wind in same rotational direction as primary winding. Spread the winding evenly across entire bobbin. Finish this winding on pin 2.
Insulation	Add 3 layers of tape, item [3], for insulation.
WD #3 Secondary Winding	Start on pin 10 and wind 10 turns (x 2 filar) of item [7]. Spread the winding evenly across entire bobbin. Wind in same rotational direction as primary winding. Finish this winding on pin 9.
Insulation	Add 3 layers of tape, item [3], for insulation.
WD #4 Primary Winding #2	Start on pin 4 and wind 40 turns (x 1 filar) of item [5] in 1 layer from left to right. On the final layer, spread the winding evenly across entire bobbin. Finish this winding on pin 1.
Insulation	Add 3 layers of tape, item [3], for insulation.
Core Assembly	Assemble and secure core halves. Item [1].
Varnish	Dip varnish uniformly in item [4]. Do not vacuum impregnate.

9 Design Spreadsheet

ACDC_TOPSwitchHX_021308 ; Rev.1.8; Copyright Power Integrations 2008	INPUT	INFO	OUTP UT	UNIT	TOP_HX_021308: TOPSwitch-HX Continuous/Discontinuous Flyback Transformer Design Spreadsheet
ENTER APPLICATION VARIABLES					Customer
VACMIN	85			Volts	Minimum AC Input Voltage
VACMAX	265			Volts	Maximum AC Input Voltage
fL	50			Hertz	AC Mains Frequency
VO	12.00			Volts	Output Voltage (main)
PO_AVG	20.00			Watts	Average Output Power
PO_PEAK			20.00	Watts	Peak Output Power
n	0.80			%/100	Efficiency Estimate
Z	0.50				Loss Allocation Factor
VB	11	<i>Info</i>		Volts	Ensure proper operation at no load.
tC	3.00			mSeconds	Bridge Rectifier Conduction Time Estimate
CIN	47.0		47	uFarads	Input Filter Capacitor
ENTER TOPSWITCH-HX VARIABLES					
TOPSwitch-HX	TOP255 PN/GN			Universal / Peak	115 Doubled/230V
<i>Chosen Device</i>		<i>TOP255 PN/GN</i>	<i>Power Out</i>	22 W / 35 W	30W
KI	0.73				External Ilimit reduction factor (KI=1.0 for default ILIMIT, KI <1.0 for lower ILIMIT)
ILIMITMIN_EXT			0.780	Amps	Use 1% resistor in setting external ILIMIT
ILIMITMAX_EXT			0.899	Amps	Use 1% resistor in setting external ILIMIT
Frequency (F)=132kHz, (H)=66kHz	H		H		Half frequency option is only available for P, G and M packages in addition to TOP259-TOP261YN devices. For full frequency operation choose E package or TOP254-TOP258YN devices.
fS			66000	Hertz	TOPSwitch-HX Switching Frequency: Choose between 132 kHz and 66 kHz
fSmin			59400	Hertz	TOPSwitch-HX Minimum Switching Frequency
fSmax			72600	Hertz	TOPSwitch-HX Maximum Switching Frequency
High Line Operating Mode			FF		Full Frequency, Jitter enabled
VOR	100.00			Volts	Reflected Output Voltage
VDS			10	Volts	TOPSwitch on-state Drain to Source Voltage
VD	0.50			Volts	Output Winding Diode Forward Voltage Drop
VDB	0.70			Volts	Bias Winding Diode Forward Voltage Drop
KP	0.58				Ripple to Peak Current Ratio (0.3 < KRP < 1.0 : 1.0 < KDP < 6.0)
PROTECTION FEATURES					
LINE SENSING					Note - For P/G package devices only one of either Line sensing or Overload power limiting protection features can be used. For all other packages both these functions can be simultaneously used.
VUV_STARTUP			95	Volts	Minimum DC Bus Voltage at which the power supply will start-up
VOV_SHUTDOWN			445	Volts	Typical DC Bus Voltage at which power supply will shut-down (Max)
RLS			4.0	M-ohms	Use two standard, 2 M-Ohm, 5% resistors in series for line sense functionality.
OUTPUT OVERVOLTAGE					
VZ			20	Volts	Zener Diode rated voltage for Output Overvoltage shutdown protection
RZ			5.1	k-ohms	Output OVP resistor. For latching



					shutdown use 20 ohm resistor instead
OVERLOAD POWER LIMITING					
Overload Current Ratio at VMAX			1.2		Enter the desired margin to current limit at VMAX. A value of 1.2 indicates that the current limit should be 20% higher than peak primary current at VMAX
Overload Current Ratio at VMIN			1.00		Margin to current limit at low line.
ILIMIT_EXT_VMIN			0.73	A	Peak primary Current at VMIN
ILIMIT_EXT_VMAX			0.75	A	Peak Primary Current at VMAX
RIL			8.65	k-ohms	Current limit/Power Limiting resistor.
RPL			N/A	M-ohms	Resistor not required. Use RIL resistor only
ENTER TRANSFORMER CORE/CONSTRUCTION VARIABLES					
Core Type	Auto		EF25		Core Type
Core		EF25		P/N:	PC40EF25-Z
Bobbin		EF25_BOB BIN		P/N:	*
AE			0.518	cm^2	Core Effective Cross Sectional Area
LE			5.78	cm	Core Effective Path Length
AL			2000	nH/T^2	Ungapped Core Effective Inductance
BW			15.6	mm	Bobbin Physical Winding Width
M	0.00			mm	Safety Margin Width (Half the Primary to Secondary Creepage Distance)
L	2.00				Number of Primary Layers
NS	10		10		Number of Secondary Turns
DC INPUT VOLTAGE PARAMETERS					
VMIN			84	Volts	Minimum DC Input Voltage
VMAX			375	Volts	Maximum DC Input Voltage
CURRENT WAVEFORM SHAPE PARAMETERS					
DMAX			0.58		Maximum Duty Cycle (calculated at PO PEAK)
IAVG			0.30	Amps	Average Primary Current (calculated at average output power)
IP			0.73	Amps	Peak Primary Current (calculated at Peak output power)
IR			0.42	Amps	Primary Ripple Current (calculated at average output power)
IRMS			0.40	Amps	Primary RMS Current (calculated at average output power)
TRANSFORMER PRIMARY DESIGN PARAMETERS					
LP			1563	uHenries	Primary Inductance
LP Tolerance	5		5		Tolerance of Primary Inductance
NP			80		Primary Winding Number of Turns
NB			9		Bias Winding Number of Turns
ALG			244	nH/T^2	Gapped Core Effective Inductance
BM			2756	Gauss	Maximum Flux Density at PO, VMIN (BM<3000)
BP			3558	Gauss	Peak Flux Density (BP<4200) at ILIMITMAX and LP_MAX. Note: Recommended values for adapters and external power supplies <=3600 Gauss
BAC			799	Gauss	AC Flux Density for Core Loss Curves (0.5 X Peak to Peak)
ur			1776		Relative Permeability of Ungapped Core
LG			0.23	mm	Gap Length (Lg > 0.1 mm)
BWE			31.2	mm	Effective Bobbin Width
OD			0.39	mm	Maximum Primary Wire Diameter including insulation
INS			0.06	mm	Estimated Total Insulation Thickness (= 2 * film thickness)
DIA			0.33	mm	Bare conductor diameter



AWG			28	AWG	Primary Wire Gauge (Rounded to next smaller standard AWG value)
CM			161	Cmils	Bare conductor effective area in circular mils
CMA			399	Cmils/Amp	Primary Winding Current Capacity (200 < CMA < 500)
Primary Current Density (J)			5.03	Amps/mm ²	Primary Winding Current density (3.8 < J < 9.75)
TRANSFORMER SECONDARY DESIGN PARAMETERS (SINGLE OUTPUT EQUIVALENT)					
Lumped parameters					
ISP			5.85	Amps	Peak Secondary Current
ISRMS			2.78	Amps	Secondary RMS Current
IO_PEAK			1.67	Amps	Secondary Peak Output Current
IO			1.67	Amps	Average Power Supply Output Current
IRIPPLE			2.22	Amps	Output Capacitor RMS Ripple Current
CMS			556	Cmils	Secondary Bare Conductor minimum circular mils
AWGS			22	AWG	Secondary Wire Gauge (Rounded up to next larger standard AWG value)
DIAS			0.65	mm	Secondary Minimum Bare Conductor Diameter
ODS			1.56	mm	Secondary Maximum Outside Diameter for Triple Insulated Wire
INSS			0.46	mm	Maximum Secondary Insulation Wall Thickness
VOLTAGE STRESS PARAMETERS					
VDRAIN			575	Volts	Maximum Drain Voltage Estimate (Includes Effect of Leakage Inductance)
PIVS			59	Volts	Output Rectifier Maximum Peak Inverse Voltage
PIVB			55	Volts	Bias Rectifier Maximum Peak Inverse Voltage
TRANSFORMER SECONDARY DESIGN PARAMETERS (MULTIPLE OUTPUTS)					
1st output					
VO1			12	Volts	Output Voltage
IO1_AVG			1.67	Amps	Average DC Output Current
PO1_AVG			20.00	Watts	Average Output Power
VD1			0.5	Volts	Output Diode Forward Voltage Drop
NS1			10.00		Output Winding Number of Turns
ISRMS1			2.778	Amps	Output Winding RMS Current
IRIPPLE1			2.22	Amps	Output Capacitor RMS Ripple Current
PIVS1			59	Volts	Output Rectifier Maximum Peak Inverse Voltage
CMS1			556	Cmils	Output Winding Bare Conductor minimum circular mils
AWGS1			22	AWG	Wire Gauge (Rounded up to next larger standard AWG value)
DIAS1			0.65	mm	Minimum Bare Conductor Diameter
ODS1			1.56	mm	Maximum Outside Diameter for Triple Insulated Wire
2nd output					
VO2				Volts	Output Voltage
IO2_AVG				Amps	Average DC Output Current
PO2_AVG			0.00	Watts	Average Output Power
VD2			0.7	Volts	Output Diode Forward Voltage Drop
NS2			0.56		Output Winding Number of Turns
ISRMS2			0.000	Amps	Output Winding RMS Current
IRIPPLE2			0.00	Amps	Output Capacitor RMS Ripple Current
PIVS2			3	Volts	Output Rectifier Maximum Peak Inverse Voltage
CMS2			0	Cmils	Output Winding Bare Conductor minimum circular mils



AWGS2			N/A	AWG	Wire Gauge (Rounded up to next larger standard AWG value)
DIAS2			N/A	mm	Minimum Bare Conductor Diameter
ODS2			N/A	mm	Maximum Outside Diameter for Triple Insulated Wire
3rd output					
VO3				Volts	Output Voltage
IO3_AVG				Amps	Average DC Output Current
PO3_AVG			0.00	Watts	Average Output Power
VD3			0.7	Volts	Output Diode Forward Voltage Drop
NS3			0.56		Output Winding Number of Turns
ISRMS3			0.000	Amps	Output Winding RMS Current
IRIPPLE3			0.00	Amps	Output Capacitor RMS Ripple Current
PIVS3			3	Volts	Output Rectifier Maximum Peak Inverse Voltage
CMS3			0	Cmils	Output Winding Bare Conductor minimum circular mils
AWGS3			N/A	AWG	Wire Gauge (Rounded up to next larger standard AWG value)
DIAS3			N/A	mm	Minimum Bare Conductor Diameter
ODS3			N/A	mm	Maximum Outside Diameter for Triple Insulated Wire
Total Continuous Output Power			20	Watts	Total Continuous Output Power
Negative Output			N/A		If negative output exists enter Output number; eg: If VO2 is negative output, enter 2



10 Power Supply Performance

All tests were performed open frame at room temperature (+25 °C) and 60 Hz line frequency, unless noted otherwise.

10.1 Energy Efficiency

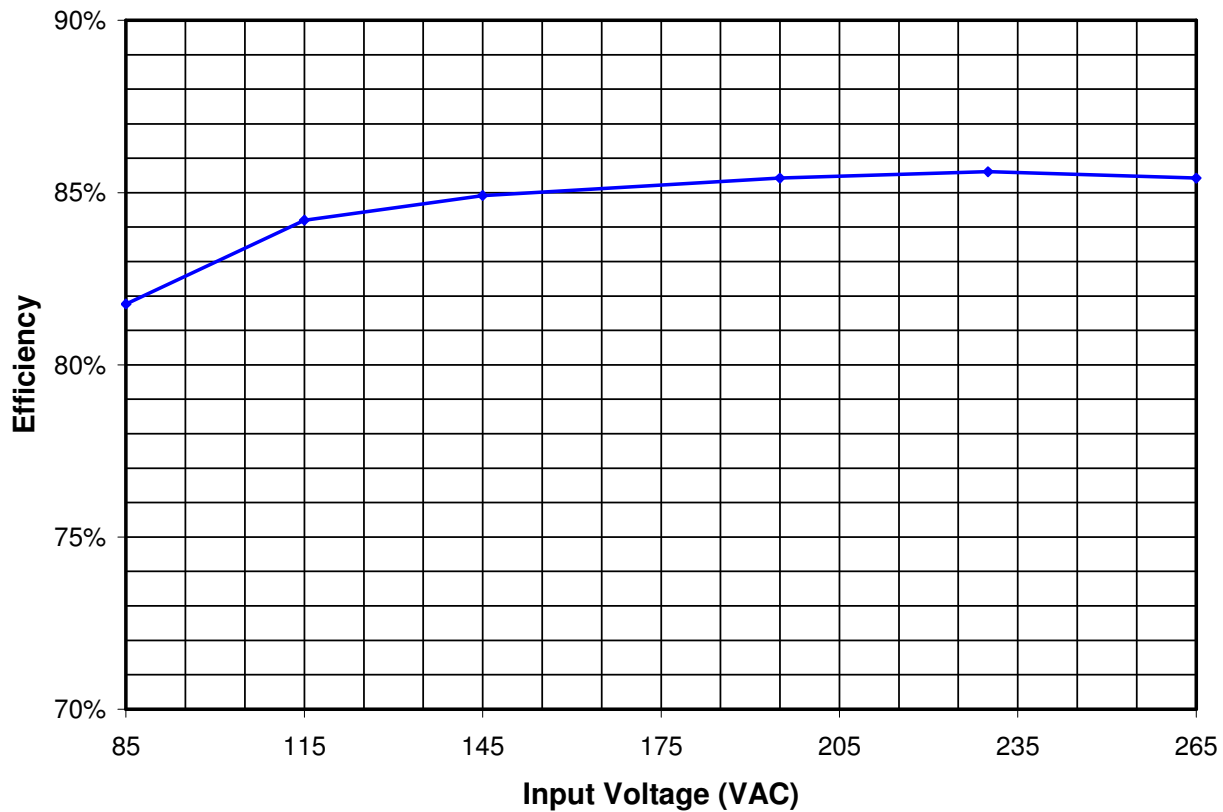

Figure 6 – Full Load Efficiency Over Input Voltage Range.



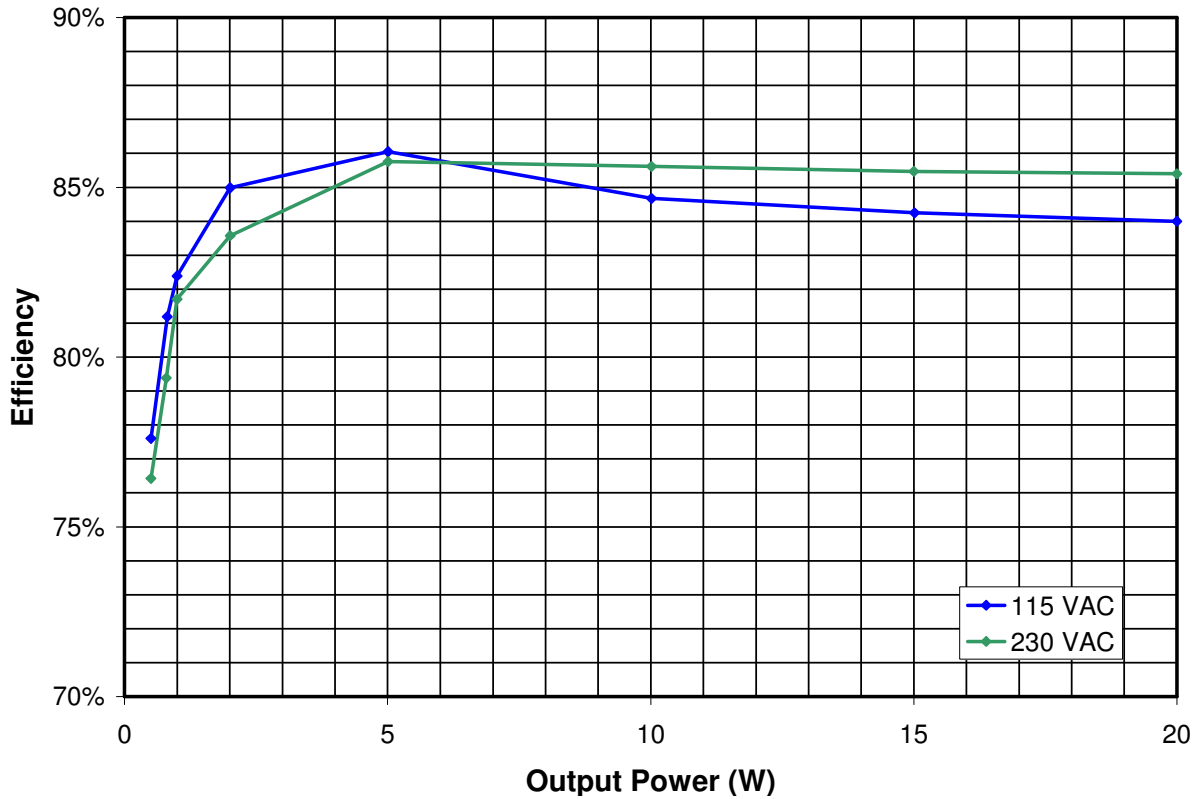

Figure 7 – Efficiency Over Load.

Table 2 lists the average active-on efficiency as defined by the Energy Star 2.0 specification (Final April 23, 2008).

Input Voltage	Efficiency at Relative Load Point				Average Efficiency
	25%	50%	75%	100%	
115 VAC	86.05%	84.67%	84.25%	84.00%	85%
230 VAC	85.76%	85.61%	85.47%	85.40%	86%
Minimum efficiency Energy Star 2.0: $0.0626 * \ln(20) + 0.622$					81%

Table 2 – Average Active-on Efficiency.



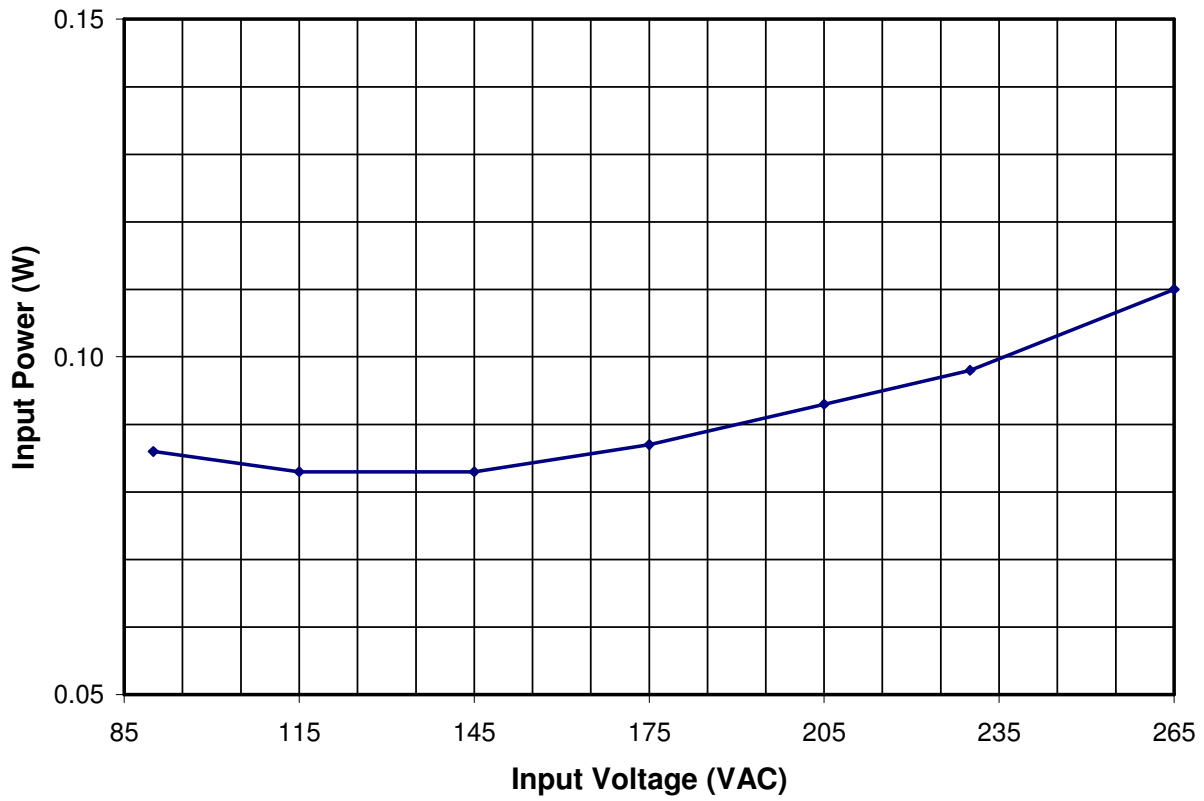

Figure 8 – No-load Input Power Consumption Over Line.



Figure 9 depicts the available output power in standby with the input power limited to 1.0 W.

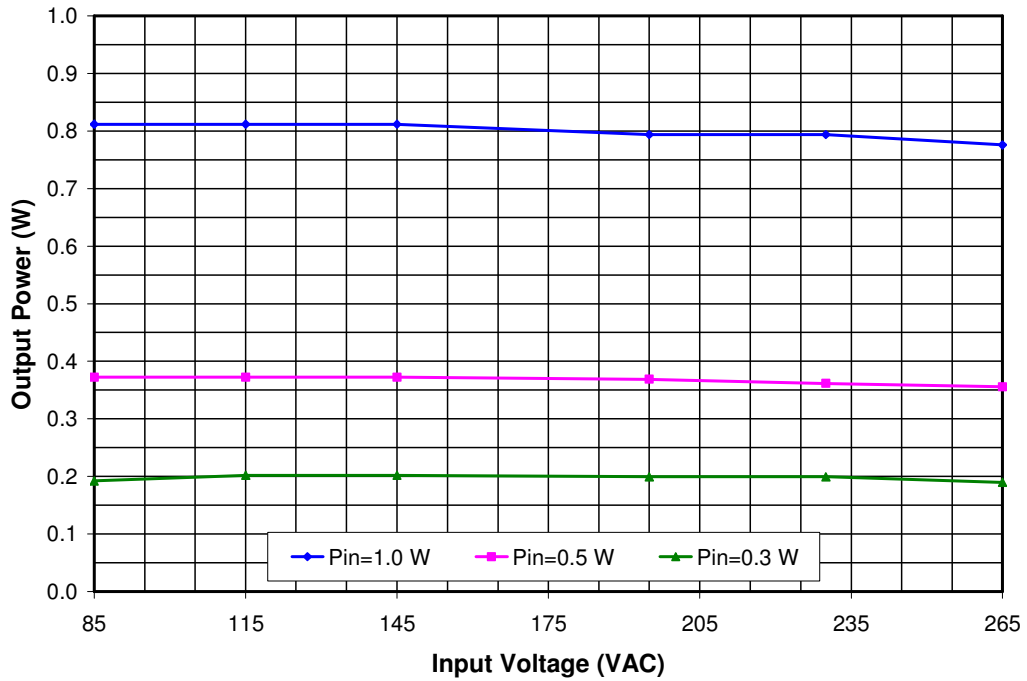

Figure 9 – Standby Output Power Over Line and Input Power.

10.2 Output Regulation and Quality

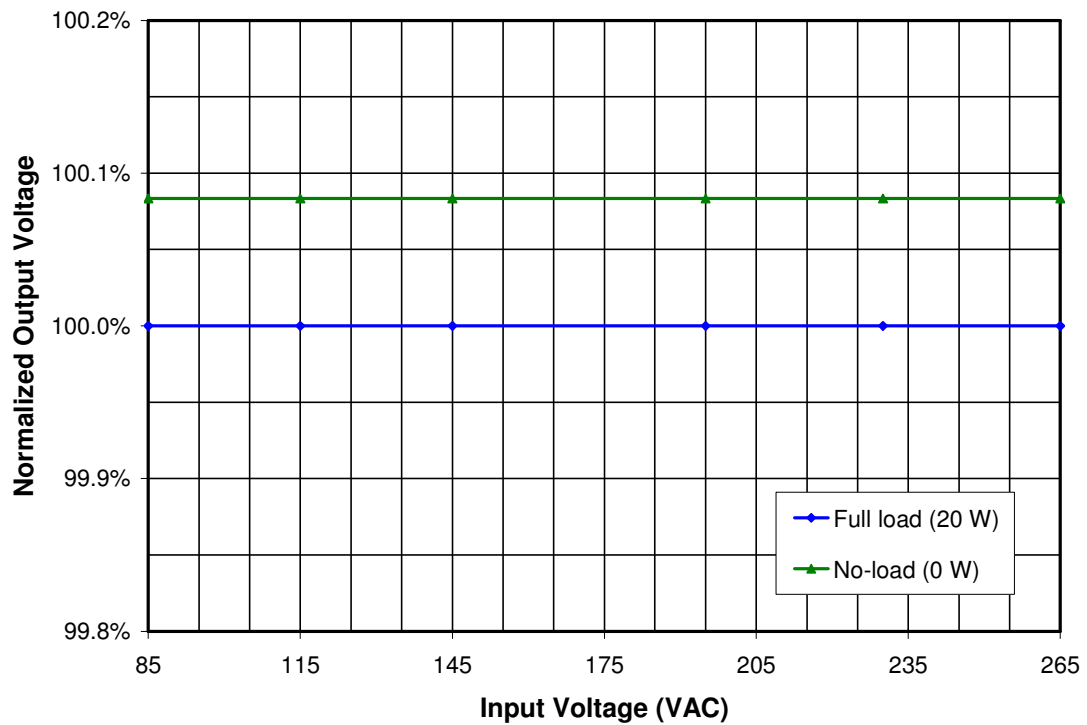

Figure 10 – Regulation Over Line and Load.



Figures 11 to 15 depict output noise and ripple performance at various load and line conditions. The measurements were taken with a local voltage probe decoupling capacitance of 1 μ F/50 V (electrolytic) and 0.1 μ F/50 V (ceramic) with a 20 MHz DSO input filter.

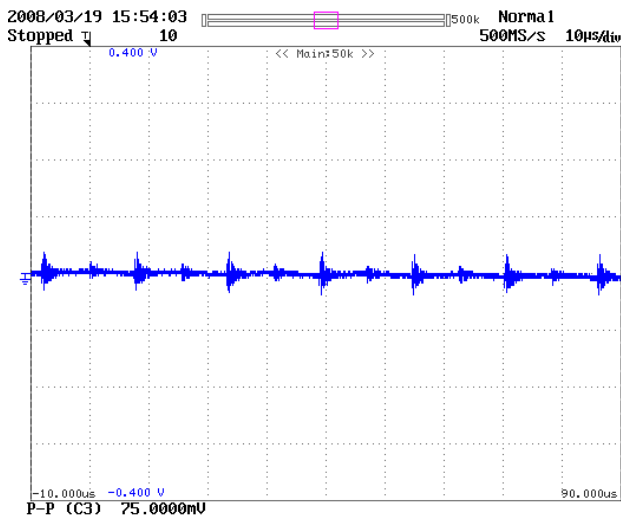

Figure 11 – Output Noise at 20 W, 85 VAC.
 V_{OUT} (100 mV/Div, 10 μ s/div).

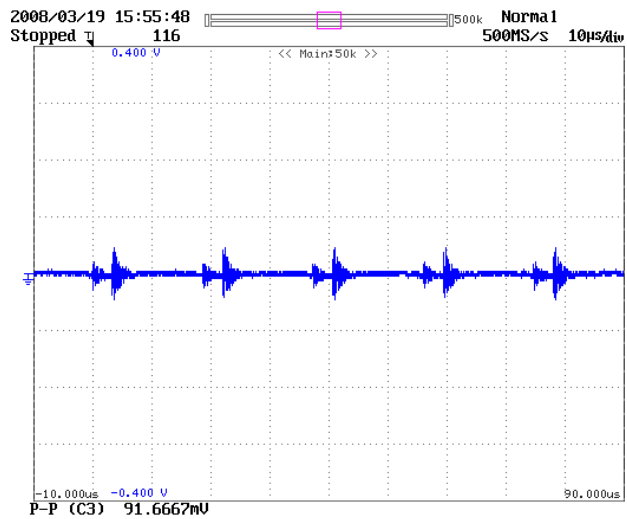

Figure 12 – Output Noise at 20 W, 265 VAC.
 V_{OUT} (100 mV/Div, 10 μ s/div).

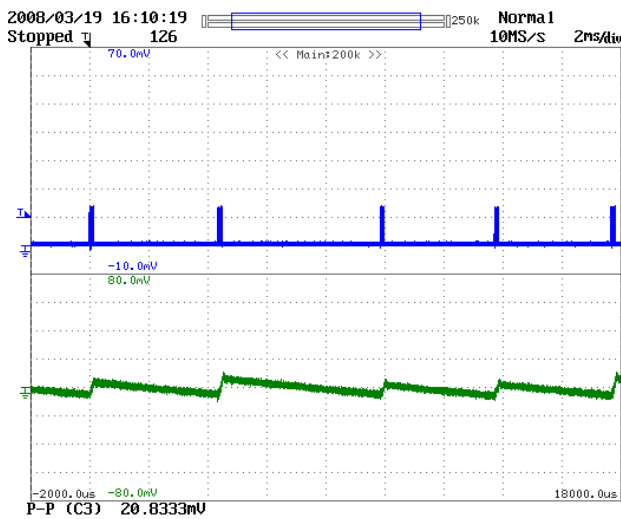

Figure 13 – Output Noise at No-load, 85 VAC.
 Upper: I_D (0.2 A/Div, 2 ms/div).
 Lower: V_{OUT} (20 mV/div).

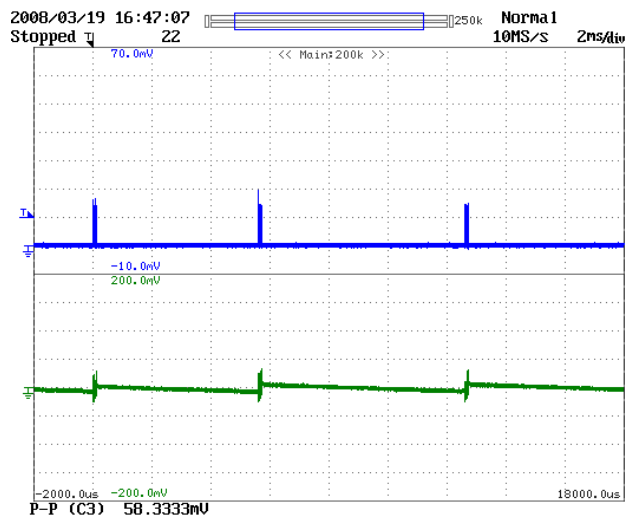

Figure 14 – Output Noise at No-load, 265 VAC.
 Upper: I_D (0.2 A /Div, 2 ms/div).
 Lower: V_{OUT} (50 mV/div).



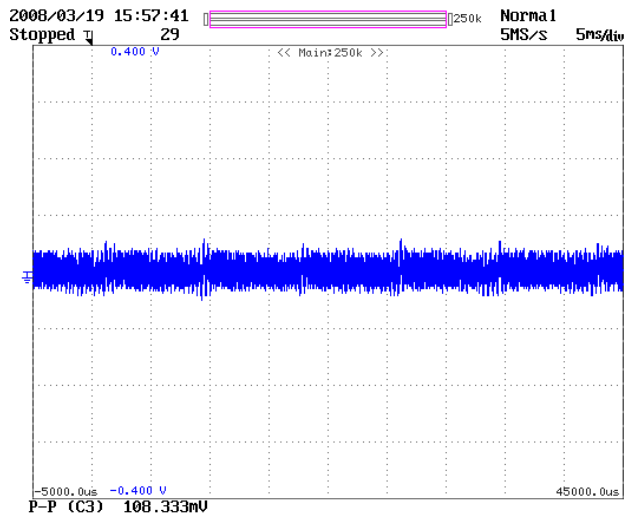

Figure 15 – Output Ripple at 20 W, 85 VAC.
 V_{OUT} (0.1 V/Div, 5 ms/div).



10.3 Transient Load

Figures 16 through 19 depict the step-load performance at various load combination and line-voltage conditions. The current slew rate was set to 10 mA/μs.

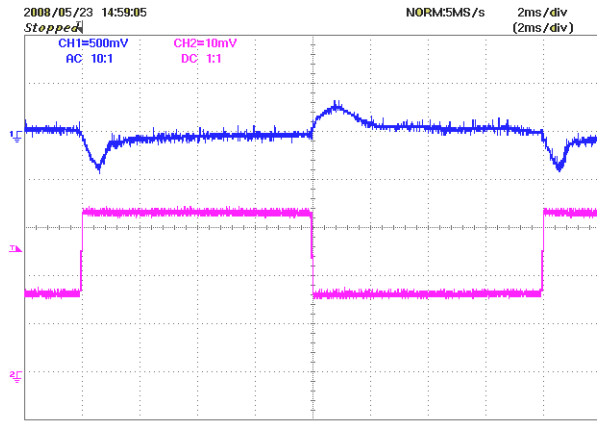

Figure 16 – Step Load 50-100%, 85 VAC.
Upper: V_{OUT} (0.5 V/div, 2 ms/div).
Lower: I_{LOAD} (0.5 A/div).

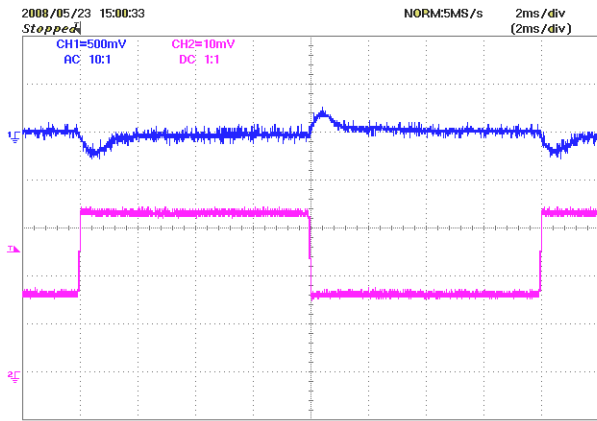

Figure 17 – Step Load 50-100%, 265 VAC.
Upper: V_{OUT} (0.5 V/div, 2 ms/div).
Lower: I_{LOAD} (0.5 A/div).

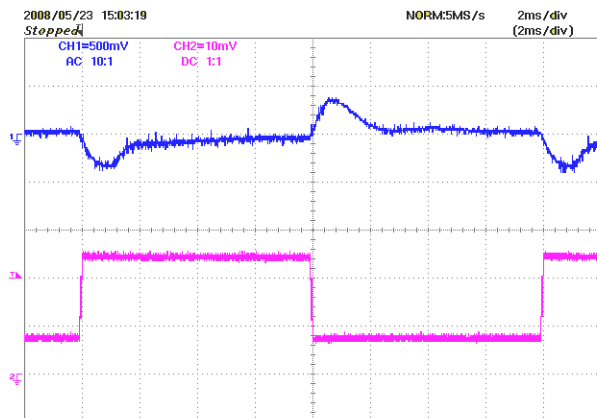

Figure 18 – Step Load 25-75%, 85 VAC.
Upper: V_{OUT} (0.5 V/div, 2 ms/div).
Lower: I_{LOAD} (0.5 A/div).

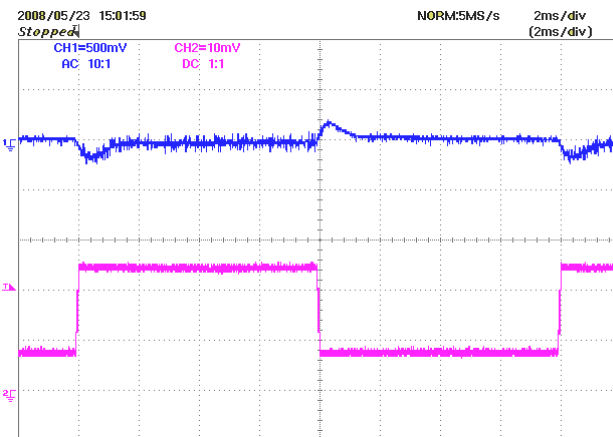

Figure 19 – Step Load 25-75%, 265 VAC.
Upper: V_{OUT} (0.5 V/div, 2 ms/div).
Lower: I_{LOAD} (0.5 A/div).



10.4 Startup

Figures 20 through 23 depict the startup performance at various load and line conditions.

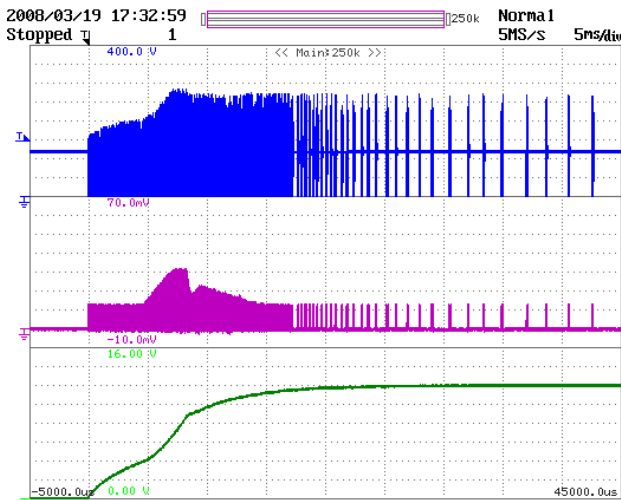

Figure 20 – Startup at no-load, 85 VAC.
Upper: V_{DS} (50 V/div, 5 ms/div).
Middle: I_D (0.2 A/div).
Lower: V_{OUT} (2 V/div).

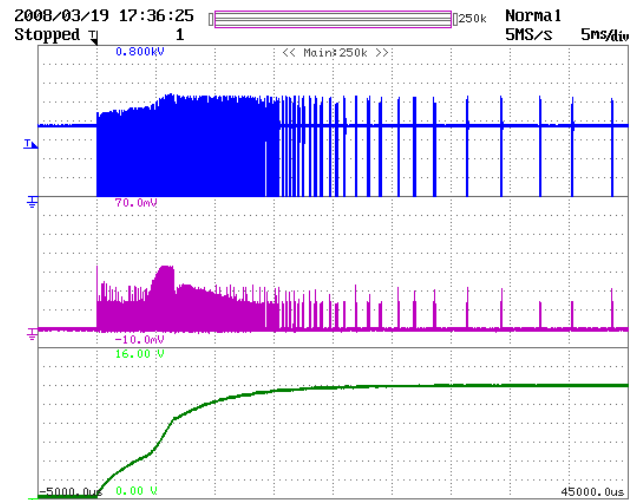

Figure 21 – Startup at no-load, 265 VAC.
Upper: V_{DS} (100 V/div, 5 ms/div).
Middle: I_D (0.2 A/div).
Lower: V_{OUT} (2 V/div).

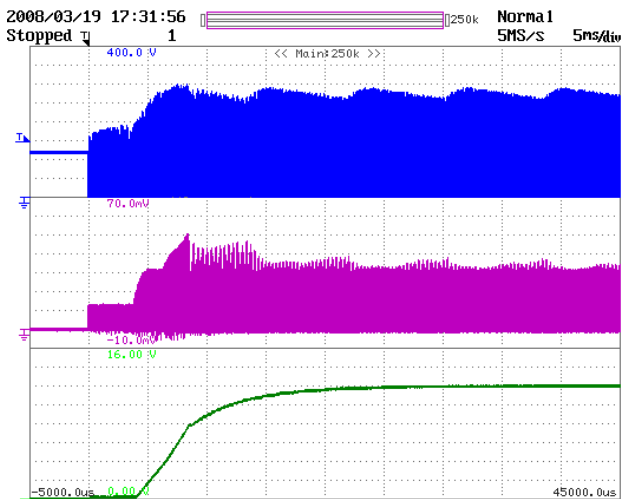

Figure 22 – Startup at 20 W, 85 VAC.
Upper: V_{DS} (50 V/div, 5 ms/div).
Middle: I_D (0.2 A/div).
Lower: V_{OUT} (2 V/div).

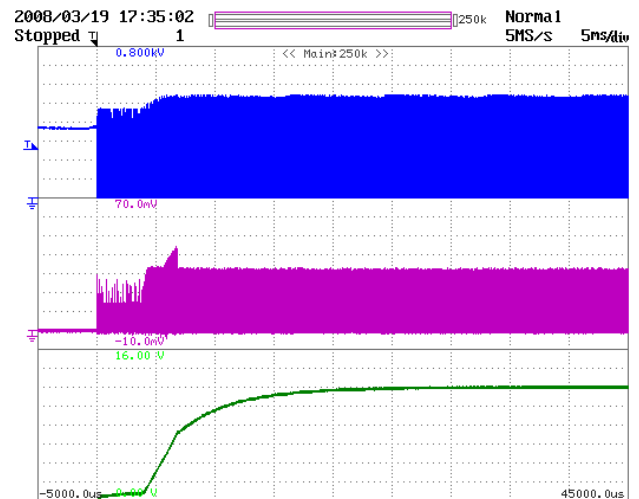

Figure 23 – Startup at 20 W, 265 VAC.
Upper: V_{DS} (100 V/div, 5 ms/div).
Middle: I_D (0.2 A/div).
Lower: V_{OUT} (2 V/div).



11 Conducted EMI

Conducted EMI was measured with a 7.2 Ω resistive load (20 W).

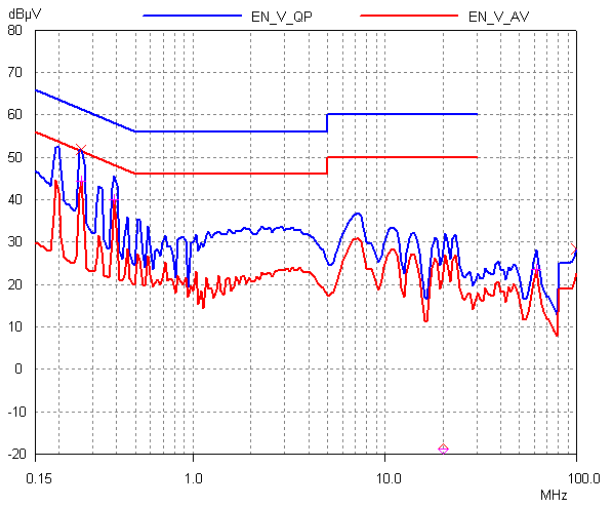

Figure 24 – Conducted EMI, 115 VAC.
Output RTN Floating.

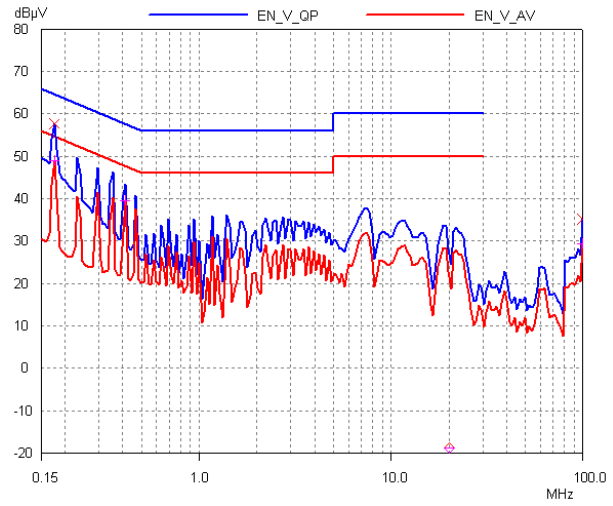

Figure 25 – Conducted EMI, 230 VAC.
Output RTN Floating.

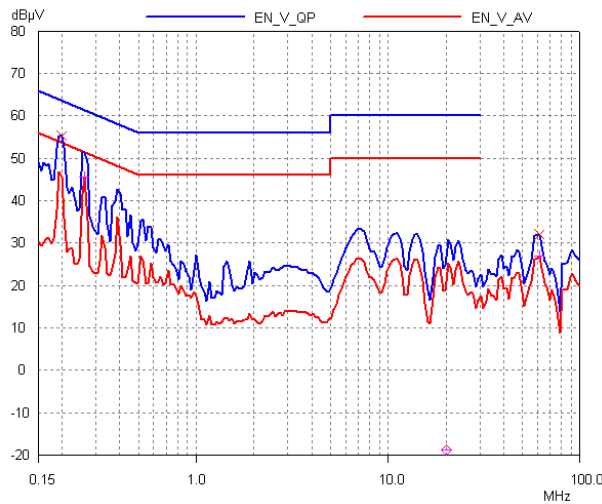

Figure 26 – Conducted EMI, 115 VAC.
Output RTN Connected to Artificial Hand.

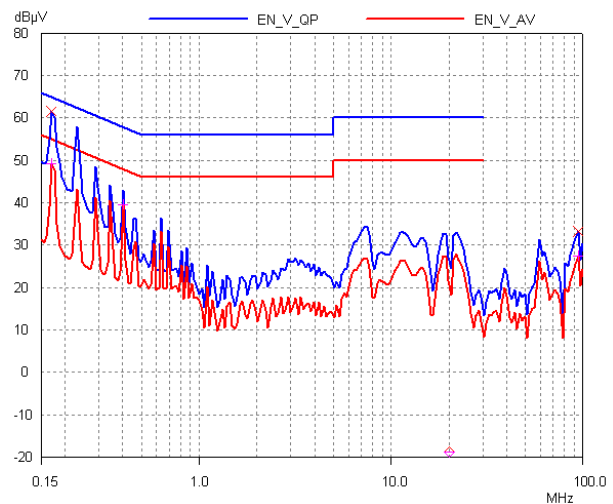

Figure 27 – Conducted EMI, 230 VAC.
Output RTN Connected to Artificial Hand.



11.1 Waveform Plots

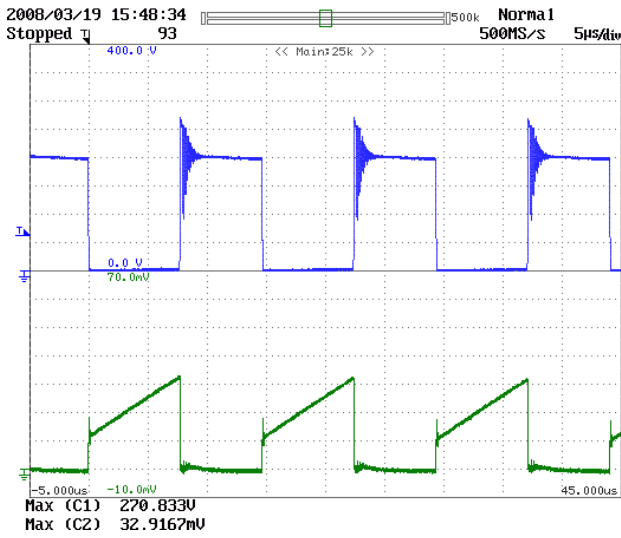

Figure 28 – Drain Waveforms at 20 W, 85 VAC.
 Upper: V_{DS} (50 V/div, 5 μ s/div).
 Lower: I_D (0.2 A/div).

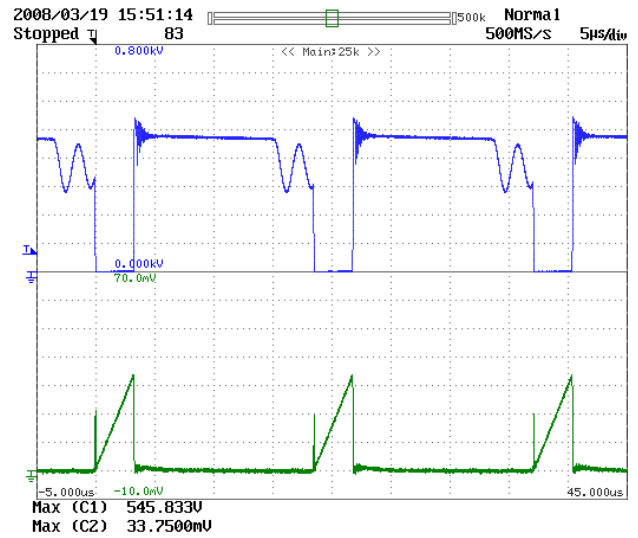

Figure 29 – Drain Waveforms at 20 W, 265 VAC.
 Upper: V_{DS} (100 V/div, 5 μ s/div).
 Lower: I_D (0.2 A/div).

Figure 32 depicts the output voltage and Drain waveforms during an output short circuit (applied at the DC load). The input power under this condition is 0.9 W.

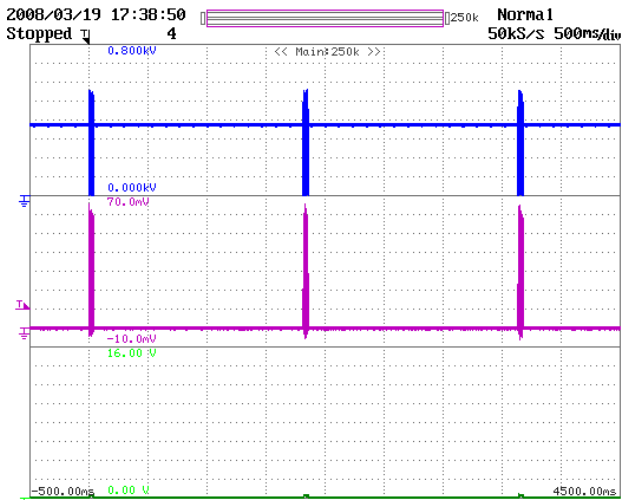

Figure 30 – Output Short Circuit, 265 VAC.
 Upper: V_{DS} (100 V/div, 500 ms/div).
 Middle: I_D (0.2 A/div).
 Lower: V_{OUT} (2 V/div).

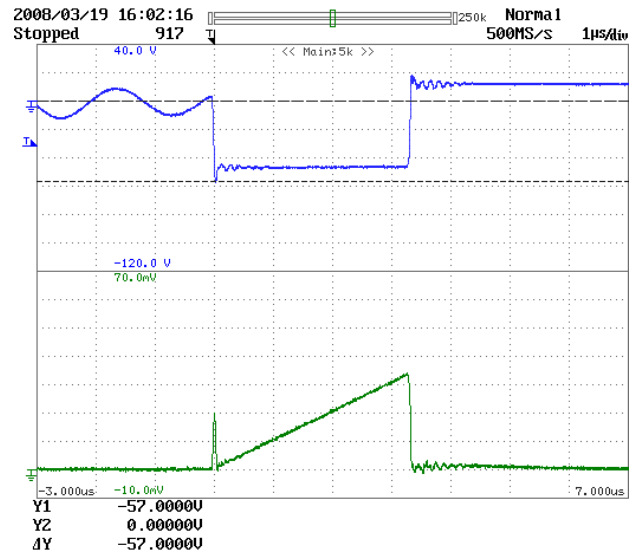

Figure 31 – Output diode reverse voltage at 20 W, 265 VAC.
 Upper: $V_{RR(D7)}$ (20 V/div, 1 μ s/div).
 Lower: I_D (0.2 A/div).



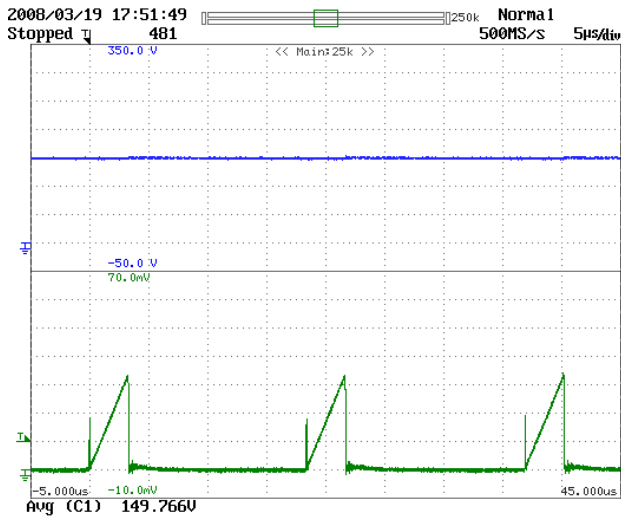

Figure 32 – Clamp Zener Voltage at 20 W, 265 VAC.
 Upper: V_{VR1} (50 V/div, 5 μ s/div).
 Lower: I_D (0.2 A/div).

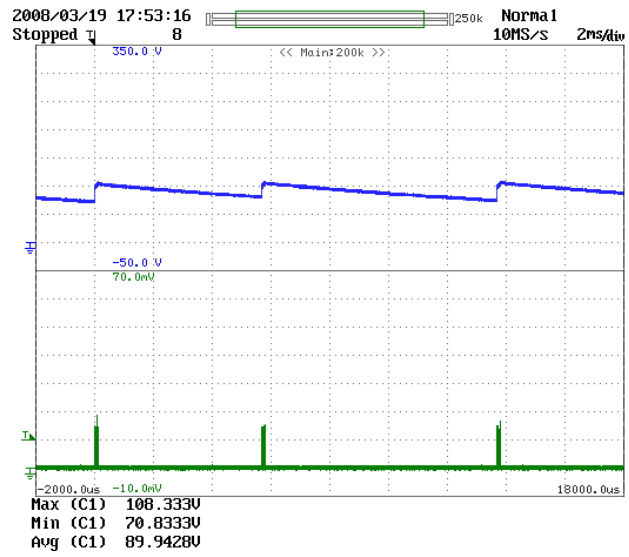

Figure 33 – Clamp Zener Voltage at 0 W, 265 VAC.
 Upper: V_{VR1} (50 V/div, 2 ns/div).
 Lower: I_D (0.2 A/div).



12 Revision History

Date	Author	Rev.	Description & changes	Reviewed
30-Sep-08	SGK	1.0	Initial Release	



For the latest updates, visit our website: www.powerint.com

Power Integrations reserves the right to make changes to its products at any time to improve reliability or manufacturability. Power Integrations does not assume any liability arising from the use of any device or circuit described herein. POWER INTEGRATIONS MAKES NO WARRANTY HEREIN AND SPECIFICALLY DISCLAIMS ALL WARRANTIES INCLUDING, WITHOUT LIMITATION, THE IMPLIED WARRANTIES OF MERCHANTABILITY, FITNESS FOR A PARTICULAR PURPOSE, AND NON-INFRINGEMENT OF THIRD PARTY RIGHTS.

PATENT INFORMATION

The products and applications illustrated herein (including transformer construction and circuits external to the products) may be covered by one or more U.S. and foreign patents, or potentially by pending U.S. and foreign patent applications assigned to Power Integrations. A complete list of Power Integrations' patents may be found at www.powerint.com. Power Integrations grants its customers a license under certain patent rights as set forth at <http://www.powerint.com/ip.htm>.

The PI Logo, TOPSwitch, TinySwitch, LinkSwitch, DPA-Switch, PeakSwitch, EcoSmart, Clampless, E-Shield, Filterfuse, StackFET, PI Expert and PI FACTS are trademarks of Power Integrations, Inc. Other trademarks are property of their respective companies. ©Copyright 2008 Power Integrations, Inc.

Power Integrations Worldwide Sales Support Locations

WORLD HEADQUARTERS

5245 Hellyer Avenue
San Jose, CA 95138, USA.
Main: +1-408-414-9200
Customer Service:
Phone: +1-408-414-9665
Fax: +1-408-414-9765
e-mail: usasales@powerint.com

GERMANY

Rueckertstrasse 3
D-80336, Munich
Germany
Phone: +49-89-5527-3911
Fax: +49-89-5527-3920
e-mail: eurosales@powerint.com

JAPAN

Kosei Dai-3 Bldg.,
2-12-11, Shin-Yokohama,
Kohoku-ku, Yokohama-shi,
Kanagawa 222-0033
Phone: +81-45-471-1021
Fax: +81-45-471-3717
e-mail:
japansales@powerint.com

TAIWAN

5F, No. 318, Nei Hu Rd., Sec. 1
Nei Hu Dist.
Taipei, Taiwan 114, R.O.C.
Phone: +886-2-2659-4570
Fax: +886-2-2659-4550
e-mail:
taiwansales@powerint.com

CHINA (SHANGHAI)

Rm 807-808A,
Pacheer Commercial Centre,
555 Nanjing Rd. West
Shanghai, P.R.C. 200041
Phone: +86-21-6215-5548
Fax: +86-21-6215-2468
e-mail:
chinasales@powerint.com

INDIA

#1, 14th Main Road
Vasanthanagar
Bangalore-560052 India
Phone: +91-80-41138020
Fax: +91-80-41138023
e-mail: indiasales@powerint.com

KOREA

RM 602, 6FL
Korea City Air Terminal B/D,
159-6
Samsung-Dong, Kangnam-
Gu,
Seoul, 135-728, Korea
Phone: +82-2-2016-6610
Fax: +82-2-2016-6630
e-mail:
koreasales@powerint.com

UNITED KINGDOM

1st Floor, St. James's House
East Street, Farnham
Surrey, GU9 7TJ
United Kingdom
Phone: +44 (0) 1252-730-141
Fax: +44 (0) 1252-727-689
e-mail:
eurosales@powerint.com

CHINA (SHENZHEN)

Room A, B & C 4th Floor, Block
C
Elec. Sci. Tech. Bldg.
2070 Shennan Zhong Rd.
Shenzhen, Guangdong,
China, 518031
Phone: +86-755-8379-3243
Fax: +86-755-8379-5828
e-mail:
chinasales@powerint.com

ITALY

Via De Amicis 2
20091 Bresso MI – Italy
Phone: +39-028-928-6000
Fax: +39-028-928-6009
e-mail: eurosales@powerint.com

SINGAPORE

51 Newton Road,
#15-08/10 Goldhill Plaza,
Singapore, 308900
Phone: +65-6358-2160
Fax: +65-6358-2015
e-mail:
singaporesales@powerint.com

APPLICATIONS HOTLINE

World Wide +1-408-414-9660

APPLICATIONS FAX

World Wide +1-408-414-9760

