

DI-159 Design Idea

LinkSwitch-II

2.4 W Charger/Adapter with 10 kV Common-mode Surge Immunity

Application	Device	Power Output	Input Voltage	Output Voltage	Topology
Low-cost Charger/Adapter	LNK603DG	2.4 W	85 – 265 VAC	8 V	Flyback

Design Highlights

- Revolutionary control concept enables very low cost, low part-count solution
 - Primary-side control eliminates secondary-side controller and optocoupler
 - Constant voltage (CV) accuracy: $\pm 5\%$
 - Constant current (CC) accuracy: $\pm 10\%$
 - Over-temperature protection with hysteretic recovery ensures safe PCB temperatures under all conditions
 - Auto-restart: output short circuit and open-loop protection
- Highly energy efficient
 - Average efficiency over load range: 75% (vs. the 67% Energy Star 2.0 requirement)
 - No-load input energy consumption: < 30 mW at 230 VAC
 - Ultra-low leakage current: < 5 μ A at 265 VAC input (no Y capacitor required)
- Easily meets the following specifications:
 - EN55022 and CISPR-22 Class B EMI (> 10 dB margin)
 - IEC 61000-4-5 Class 3 AC line surge (10 kV common mode)
 - IEC 61000-4-2 ESD immunity (to ± 15 kV)

Operation

The schematic in Figure 1 depicts the design for a 2.4 W universal input, constant voltage/constant current (CV/CC) charger power-supply design based on Power Integrations' LinkSwitch family

product LNK603DG. This design is useful for cordless phone base-station chargers or similar applications requiring a CV/CC characteristic.

In this design diodes D1 through D4 rectify the AC input. Capacitors C1 and C2 filter the rectified AC. Inductors L1 and L2, with capacitors C1 and C2 form pi (π) filters to attenuate conducted differential-mode EMI. This, in combination with Power Integrations' transformer E-shield™ technology, means EMI standard EN55022 class B compliance with wide margin, using no Y capacitor. Fusible, flameproof, wire-wound resistor RF1 provides protection against catastrophic failure and limits inrush currents during start-up. Although RV1 is shown in Figure 1, it is not needed unless this power supply must meet a 2 kV, rather than a 1 kV, surge immunity requirement.

Figure 1 shows U1 biased from an optional bias supply, which reduces no-load power consumption.

In the CV region, the output voltage is regulated by using ON/OFF control. Regulation is maintained by adjusting the ratio of enabled to disabled switching cycles. This also optimizes the efficiency of the converter over the entire load range by scaling switching

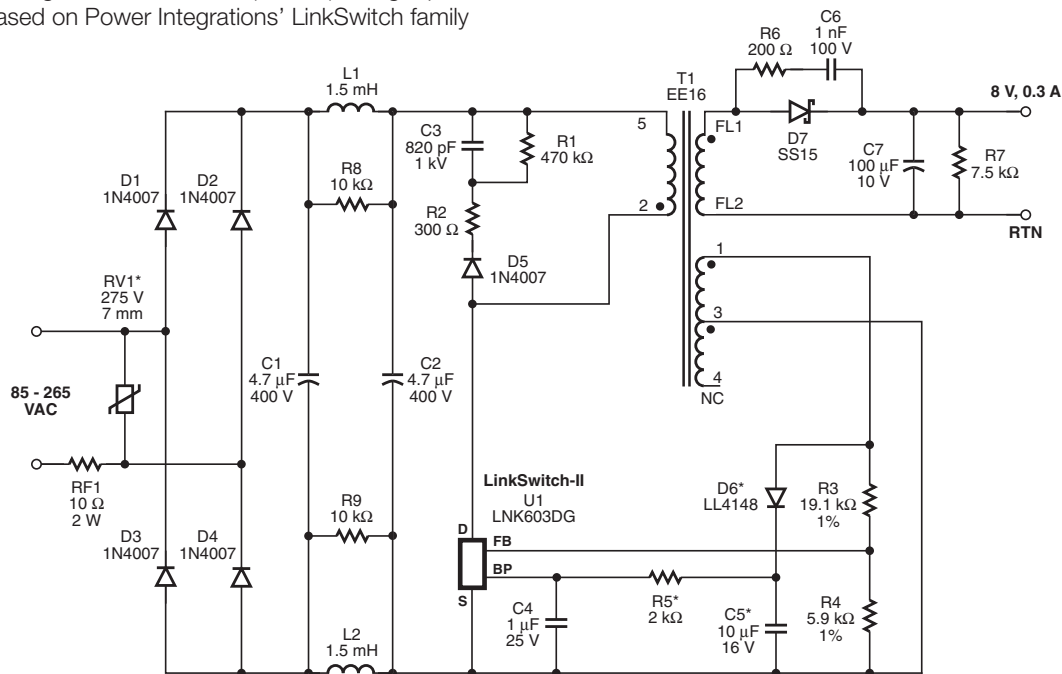

*RV1 is not required for 1 kV differential surge but is required for 2 kV differential surge

*Optional components

PI-5134-051908

Figure 1. Schematic: 2.4 W CV/CC Universal Input Charger Power Supply.

losses with output load. At light loads (trickle charge) the primary current limit is reduced to decrease the transformer flux density, which minimizes audible noise.

When no switching cycles are skipped (maximum power point) the controller within the LinkSwitch-II transitions into CC mode. A further increase in the demand for load current causes the output voltage to drop. The drop in output voltage is reflected on the FB pin voltage. In response to the reduction of voltage at the FB pin, the switching frequency is reduced to achieve linear CC output. The RCD-R clamp formed by D5, R1, R2, and C3 limits leakage inductance drain voltage spikes. Resistor R2 has a relatively large value to prevent ringing on the drain voltage waveform caused by the leakage inductance. This improves regulation and reduces EMI generation.

Diode D7 rectifies the secondary and C7 filters it. The combination of C6 and R6 limits transient voltage spikes across D7 and reduces conducted as well as radiated EMI. Resistor R7 acts as an output preload to ensure the output voltage at no-load is within acceptable limits. Feedback resistors R3 and R4 set both the maximum operating frequency (and thereby output current) in the CC region and the output voltage in the CV region.

Key Design Points

- Capacitor C7 was chosen as a low ESR type capacitor to meet the output voltage ripple requirement without LC post filtering.
- If lower average efficiency is acceptable (2% to 3% drop), replace D7 with a PN-junction diode to lower cost. Then re-adjust R3 and R4 as needed to ensure the output voltage stays centered.
- Place the BYPASS pin capacitor (C4) physically close to U1 on the PCB.

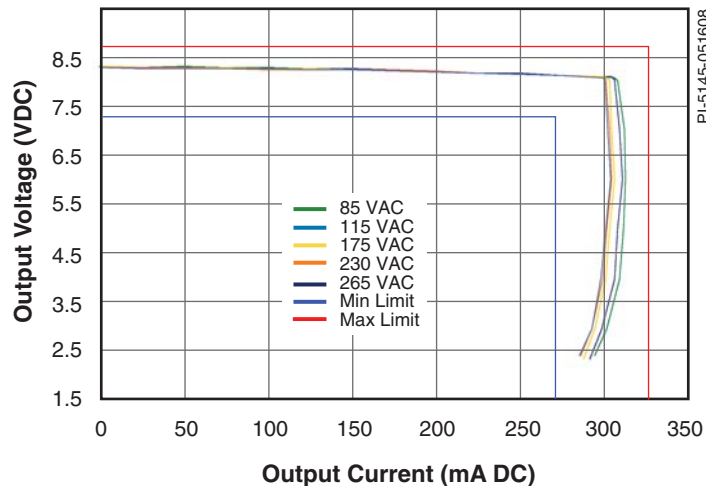

Figure 2. Typical CC/CV Characteristic Over Line at 25 °C.

- Minimize clamp and output diode loop areas to reduce EMI.
- Space the AC input away from switching nodes to minimize noise coupling that may bypass input filtering.
- The extended creepage distance on U1 between the high and low voltage pins prevents arcing and improves reliability, which is especially important in very humid conditions.
- Use 1% tolerance resistors for R3 and R4 for better voltage and current accuracy.
- Flying leads at the secondary winding prevent arcing within the transformer during common-mode surge conditions.

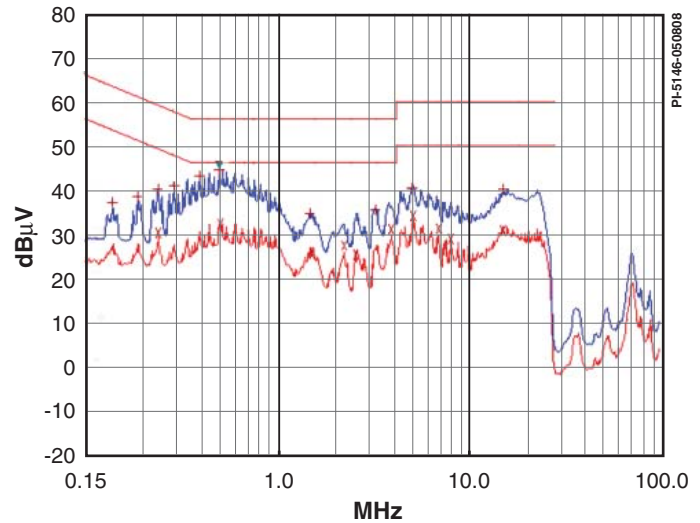

Figure 3. Conducted EMI, EN55022 B Limits: Measurements Made at 230 VAC with Output Connected to Earth Ground.

Transformer Parameters

Core Material	EE16, NC-2H or equivalent, gapped for ALG of 143 nH/t ²
Bobbin	EE16, Horizontal, 10 pins, (5/5)
Winding Details	Shield: 12T x 2, 30 AWG Primary: 108T, 35 AWG FB/Bias: 9T x 3, 31 AWG Secondary: 10T, 24 TIW
Winding Order	Shield (4-NC), Primary (2-5), Bias (1-3), 5 V (Flying leads)
Primary Inductance	2.28 mH, ±10%
Primary Resonant Frequency	800 kHz (minimum)
Leakage Inductance	65 µH (maximum)

Table 1. Transformer Parameters. (AWG = American Wire Gauge, TIW = Triple Insulated Wire, NC = No Connection)

Power Integrations
5245 Hellyer Avenue
San Jose, CA 95138, USA.
Main: +1 408-414-9200
Customer Service
Phone: +1-408-414-9665
Fax: +1-408-414-9765
Email: usasales@powerint.com

On the Web
www.powerint.com

Power Integrations reserves the right to make changes to its products at any time to improve reliability or manufacturability. Power Integrations does not assume any liability arising from the use of any device or circuit described herein. POWER INTEGRATIONS MAKES NO WARRANTY HEREIN AND SPECIFICALLY DISCLAIMS ALL WARRANTIES INCLUDING, WITHOUT LIMITATION, THE IMPLIED WARRANTIES OF MERCHANTABILITY, FITNESS FOR A PARTICULAR PURPOSE, AND NON-INFRINGEMENT OF THIRD PARTY RIGHTS. The products and applications illustrated herein (transformer construction and circuits external to the products) may be covered by one or more U.S. and foreign patents or potentially by pending U.S. and foreign patent applications assigned to Power Integrations. A complete list of Power Integrations' patents may be found at www.powerint.com. Power Integrations grants its customers a license under certain patent rights as set forth at <http://www.powerint.com/ip.htm>.

The PI logo, TOPSwitch, TinySwitch, LinkSwitch, DPA-Switch, PeakSwitch, EcoSmart, Clampless, E-Shield, Filterfuse, StackFET, PI Expert and PI FACTS are trademarks of Power Integrations, Inc. Other trademarks are property of their respective companies. ©2008, Power Integrations, Inc.