

# Design of an Audio Power System

February 2007

# Design Challenge

- **Over design was a traditional requirement for audio power systems**
  - Audio systems typically have very high peak power requirements
    - Crest factor of 10:1 is not uncommon
- **To meet these challenges the Power train needed to be large**
  - Power transformer large to support peak flux
  - Power Switching MOSFET (and hence drivers) big for high peak currents
    - Meant that CEC and Energy Star efficiency targets were hard to meet

# ON/OFF Control Suits Wide Load Range

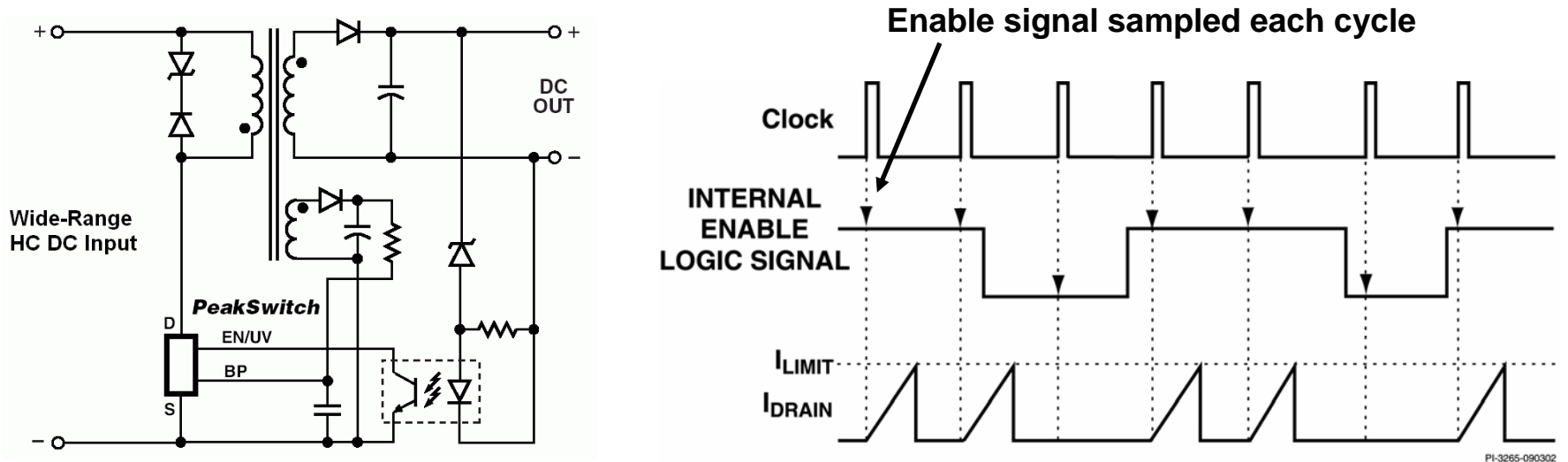

- **Current ramps to fixed current limit every ON cycle**
  - Each ON cycle delivers fixed energy
  - Cycles are disabled (OFF cycles) as necessary to maintain regulation
- **Effective switching frequency proportional to load**
  - Provides virtually constant efficiency over entire load range
- **Lowest frequency at light load ensures optimum standby efficiency**
  - Multi-level current limit practically eliminates audible noise
- **Extremely simple circuit configuration**

# Very High Frequency Operation During Peak Loads

- **AudioSwitch** operates at up to **277 kHz** switching frequency during peak loads
  - Switching frequency is automatically adjusted with load
  - Typ. < 1 kHz during no-load
- **Core size selection is based on continuous load requirements**
- **Magnetics are significantly smaller than in other solutions**
  - EE-16 for 45 W peak and EE-25 for 85 W peak demonstrated

Typical average switching frequency at distinct load points

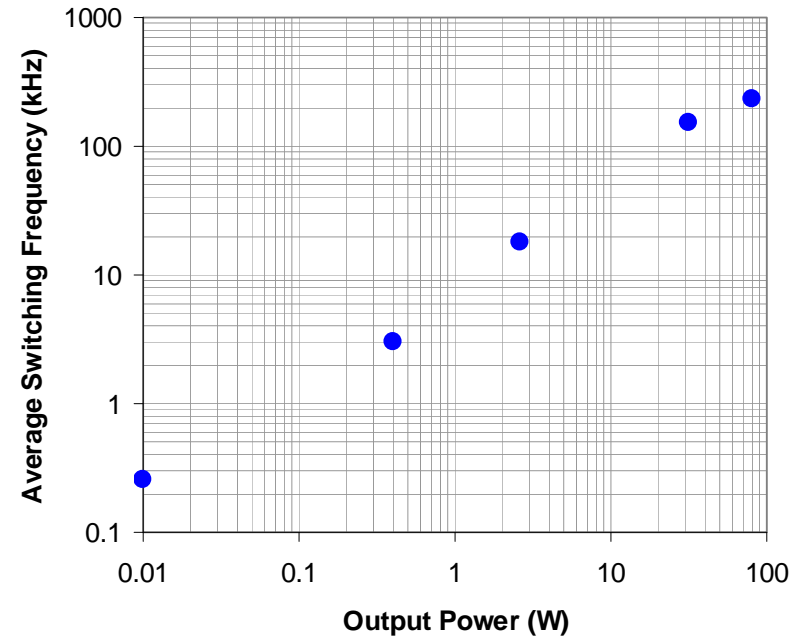

# The PeakSwitch Family

OUTPUT POWER TABLE				
PRODUCT <sup>3</sup>	230 VAC $\pm$ 15%		85-265 VAC	
	Adapter Cont. <sup>1</sup>	Adapter Peak <sup>2</sup>	Adapter Cont. <sup>1</sup>	Adapter Peak <sup>2</sup>
PKS603 P	13 W	32 W	9 W	25 W
PKS604 P	23 W	56 W	16 W	44 W
PKS604 Y/F	35 W	56 W	23 W	44 W
PKS605 P	31 W	60 W	21 W	44 W
PKS605 Y/F	46 W	79 W	30 W	58 W
PKS606 P	35 W	66 W	25 W	46 W
PKS606 Y/F	68 W	117 W	45 W	86 W
PKS607 Y/F	75 W	126 W	50 W	93 W

Table 1. **Introduced 2-26-07**

Notes:

1. Typical continuous power in a non-ventilated enclosed adapter measured at +50 °C ambient.
2. Typical peak power for a period of 100 ms and a duty cycle of 10% in a non-ventilated enclosed adapter measured at +50 °C (see Key Applications section for details).
3. See Part Ordering Information.

- **Actual continuous power capability depends on thermal constraints**
- **Actual application peak power capability depends on**
  - Peak power duration
  - Peak power duty cycle

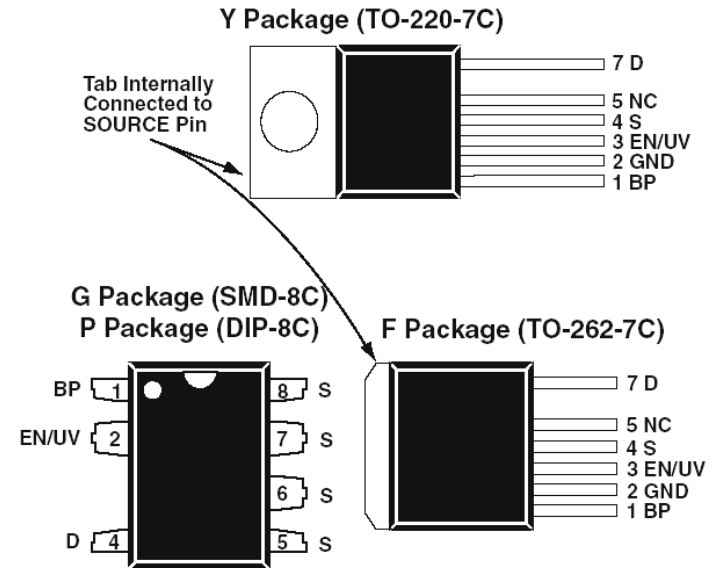

# Design Requirement for Computer Audio

- **Input 90-264Vrms**
- **Continuous power: 12V/2A (24W)**
  - Peak power: 36W
  - The duration of peak power is “as long as possible”
- **The Ripple noise should be under 40mV at full load**
- **OVP, OCP and SCP operate with auto restart**
- **The adapter should meet CEC regulations**
- **Cost to be less than \$4.00**

# Board Photograph

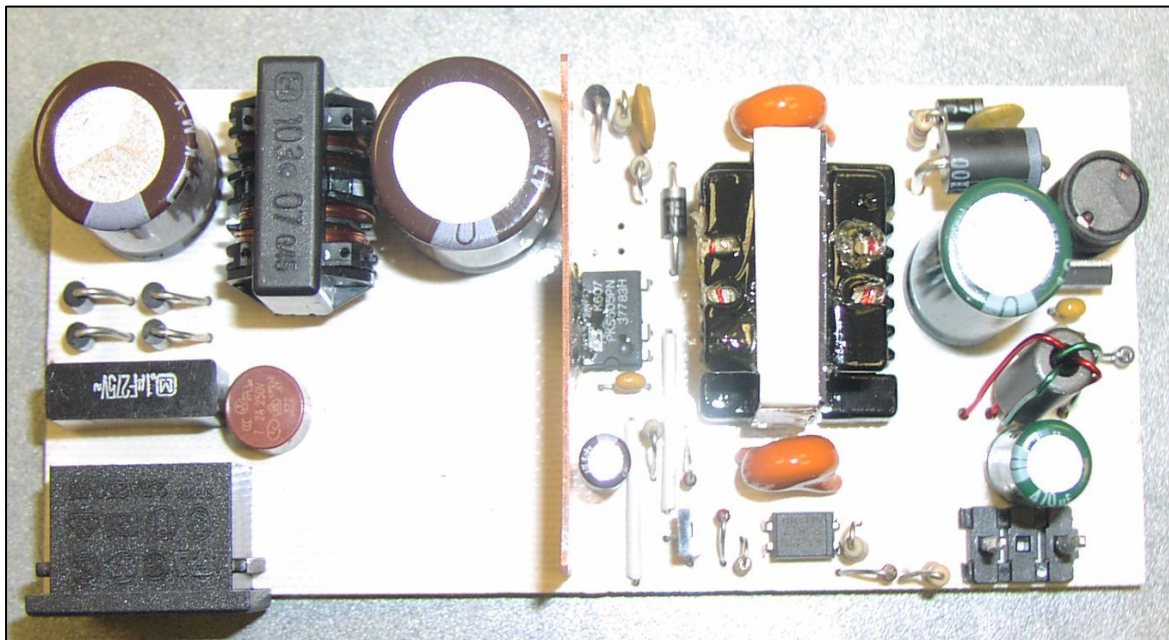

- **Single-side board**
  - Only 36 components
  - No surface mount components
- **Small EE-25 transformer**

# Schematic and Operation

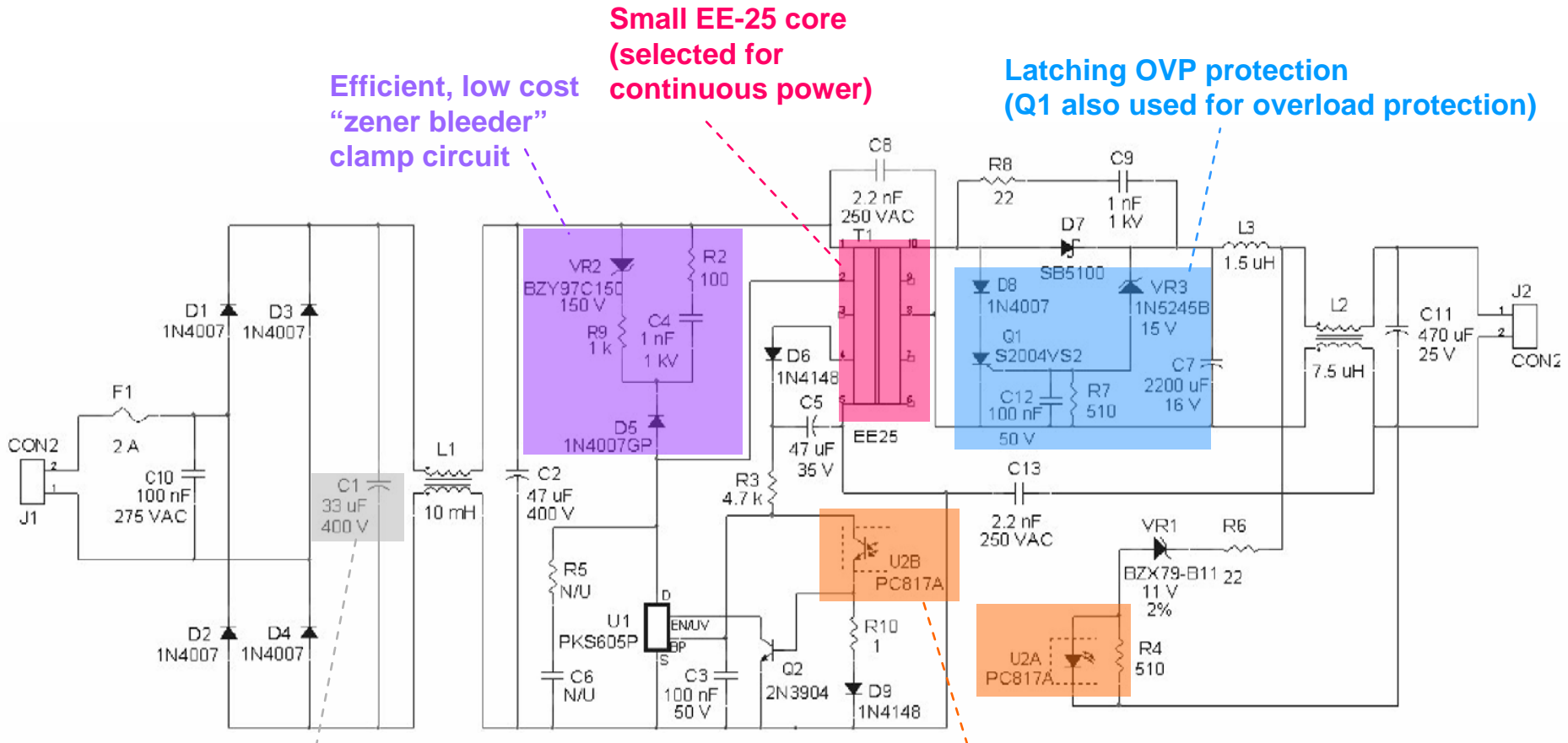

Efficient, low cost  
"zener bleeder"  
clamp circuit

Small EE-25 core  
(selected for  
continuous power)

Latching OVP protection  
(Q1 also used for overload protection)

Bulk capacitor  
selected  
to accommodate  
holdup time  
requirement

Single Opto-coupler  
(no redundancy needed)

Engineering  
report and  
detailed  
operation



# Efficiency Summary

Percent of Full Load	Efficiency (%)	
	115 VAC	230 VAC
25	83	80.5
50	84	81.8
75	84.2	83.5
100	83.7	83.8
Average	83.7	82.4
CEC specified minimum average efficiency (%)	<b>77.6</b>	

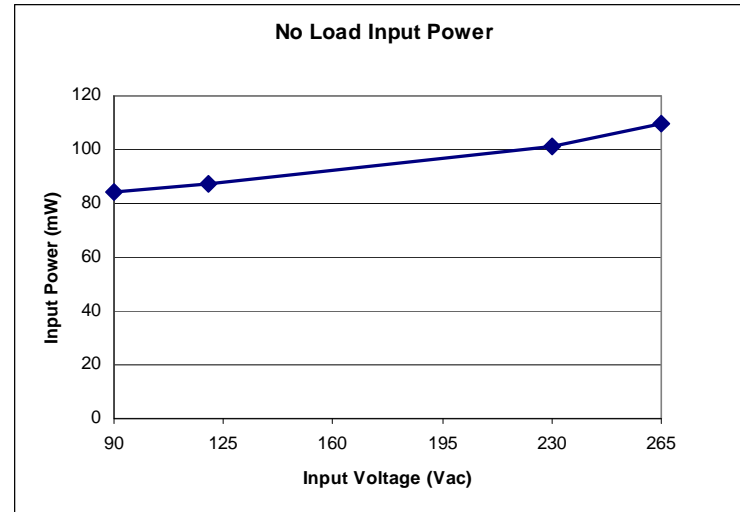

All single output adapters, including those provided with products, for sale in California after July 1<sup>st</sup>, 2006 must meet the California Energy Commission (CEC) requirement for minimum active mode efficiency and no load input power. Minimum active mode efficiency is defined as the average efficiency of 25, 50, 75 and 100% of rated output power with the limit based on the nameplate output power

# Conducted EMI Performance

- 24 W resistive load
- Output RTN connected to LISN protective earth (PE)

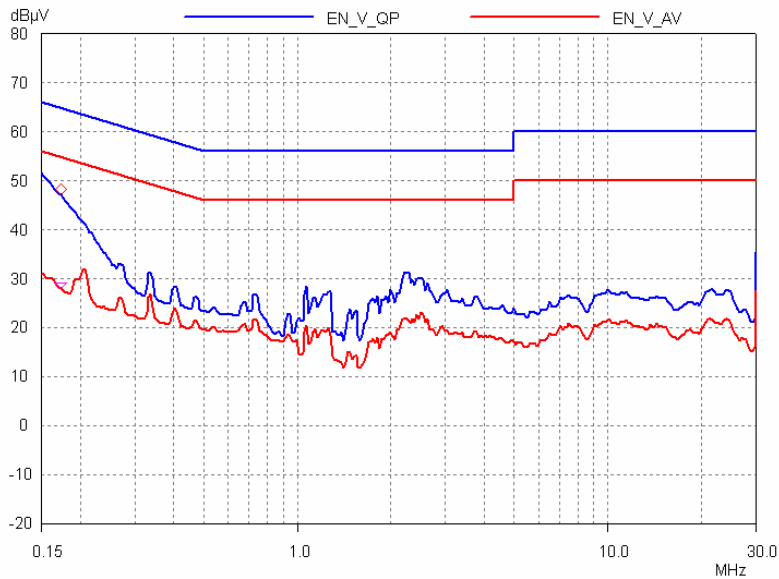

115 VAC

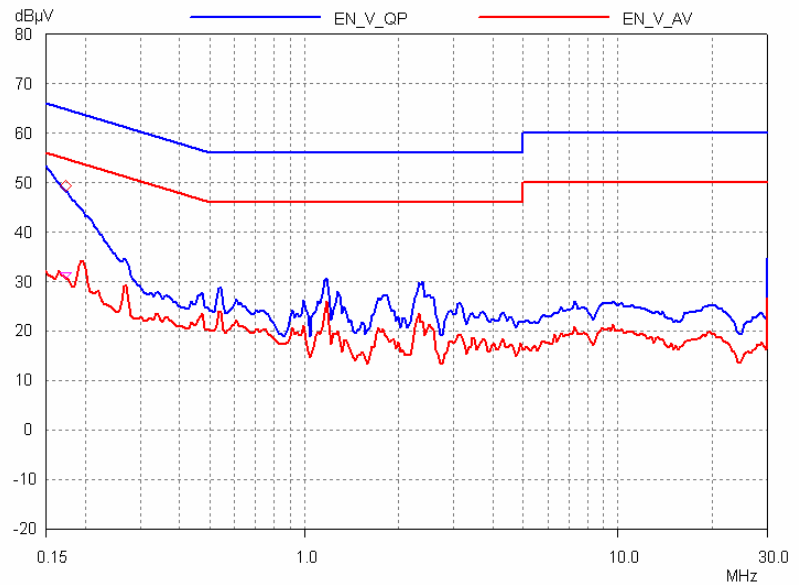

230 VAC

# Computer Audio Specification

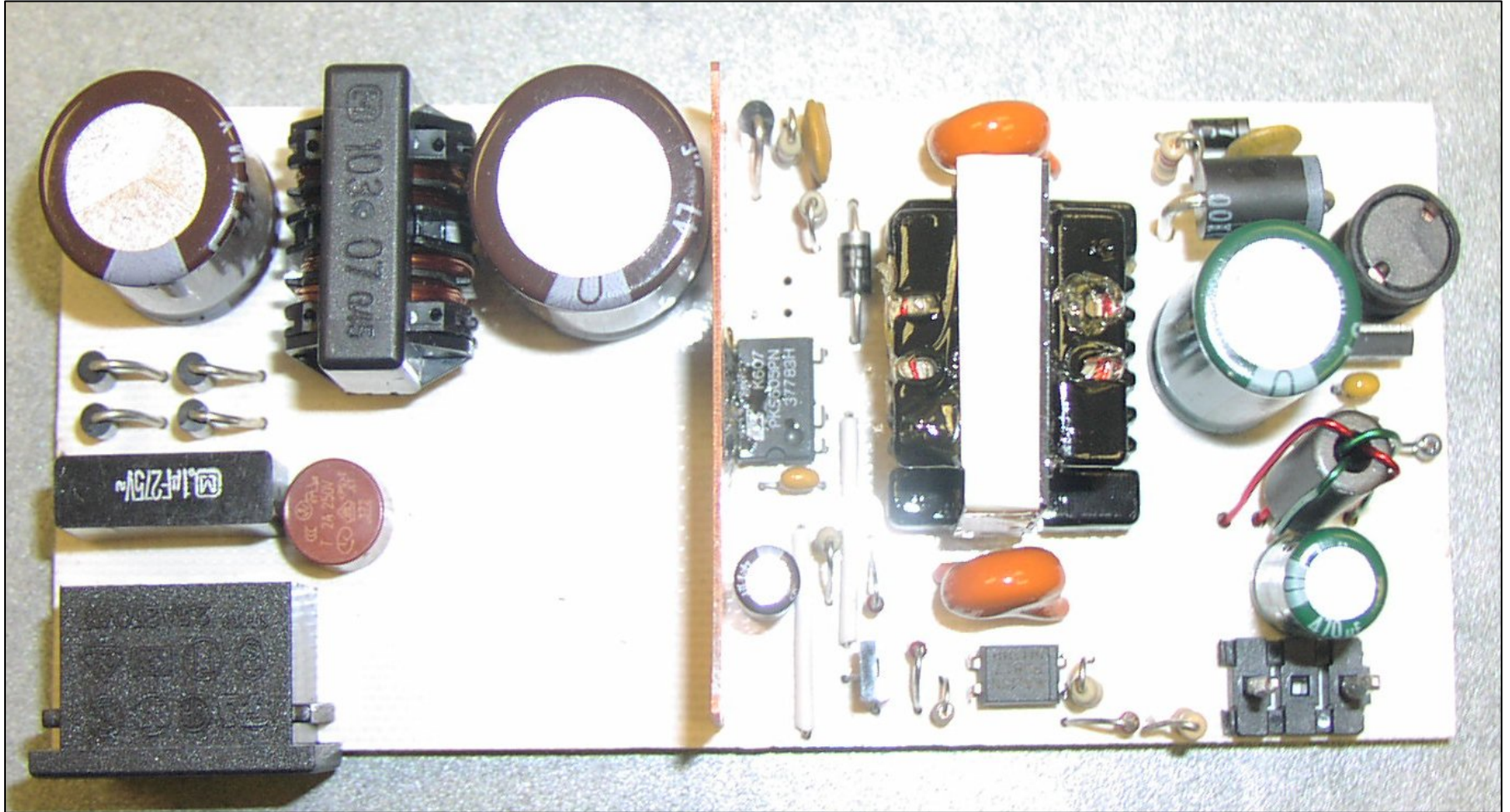

# Summary

- ***PeakSwitch* is specifically targeted for applications with large peak to continuous power ratios**
- ***PeakSwitch* provides exceptional efficiency performance over the entire load range**
  - Virtually constant efficiency operation
- **Numerous innovations increase overall performance and reduce system cost and component count**
  - Very high switching frequency operation during peak loads
  - Conditional latching shutdown with smart AC sense
  - Adaptive on-time extension
  - Adaptive current limit
- ***PeakSwitch* is a scalable solution for up to 85 W peak power**

# Thank you for your attention

For the latest updates, visit our website: [www.powerint.com](http://www.powerint.com)

Power Integrations may make changes to its products at any time. Power Integrations has no liability arising from your use of any information, device or circuit described herein nor does it convey any license under its patent rights or the rights of others. POWER INTEGRATIONS MAKES NO WARRANTIES HEREIN AND SPECIFICALLY DISCLAIMS ALL WARRANTIES INCLUDING, WITHOUT LIMITATION, THE IMPLIED WARRANTIES OF MERCHANTABILITY, FITNESS FOR A PARTICULAR PURPOSE, AND NON-INFRINGEMENT OF THIRD PARTY RIGHTS.

## **PATENT INFORMATION**

The products and applications illustrated herein (including circuits external to the products and transformer construction) may be covered by one or more U.S. and foreign patents or potentially by pending U.S. and foreign patent applications assigned to Power Integrations. A complete list of Power Integrations' patents may be found at [www.powerint.com](http://www.powerint.com).

The PI Logo, *TOPSwitch*, *TinySwitch*, *LinkSwitch*, *DPA-Switch* and *EcoSmart* are registered trademarks of Power Integrations. *PI Expert* and *PI FACTS* are trademarks of Power Integrations. © Copyright 2005 Power Integrations.