

SCALE™-2 2SD300C17

Description & Application Manual

Dual Channel High-quality and Low-cost SCALE™-2 Driver Core

Abstract

The SCALE™-2 dual-driver core 2SD300C17 is a second source to Infineon's 2ED300C17-S and 2ED300C17-ST. The driver is fully pin and function-compatible to the 2ED300C17-S/2ED300C17-ST and was designed for applications in which high reliability is expected.

The use of Power Integrations' highly integrated SCALE-2 chipset allows 63% of the components to be dispensed with compared to the 2ED300C17-S/2ED300C17-ST. This advantage is impressively reflected in increased reliability (function and MTBF) with simultaneously lower costs.

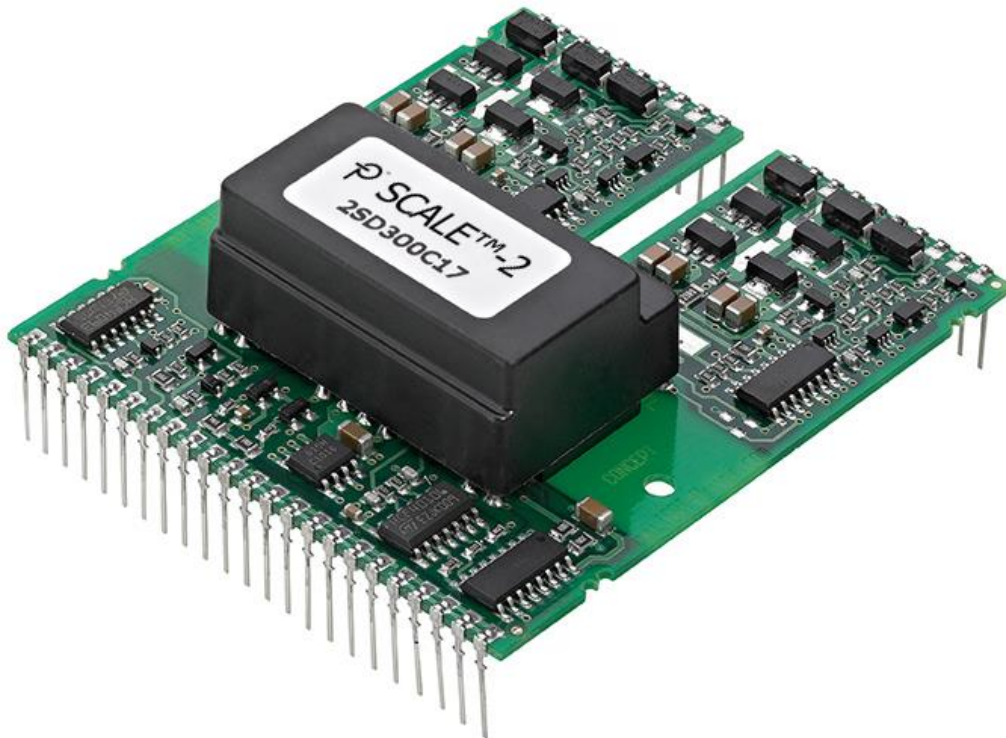

Fig. 1 2SD300C17 driver core

 Preliminary Description & Application Manual

| |
|-----------------|
| Contents |
|-----------------|

| | |
|---|-----------|
| Driver Overview | 3 |
| Recommended Interface Circuitry for the Primary Side Connector | 7 |
| Description of Primary Side Interface | 8 |
| General..... | 8 |
| VDC terminal..... | 8 |
| VDD terminal..... | 8 |
| Mod (mode selection) | 8 |
| INA, INB (channel drive inputs, e.g. PWM)..... | 9 |
| SOA, SOB (status outputs) | 9 |
| CA and CB (input for adjusting the dead time in half-bridge mode) | 10 |
| Recommended Interface Circuitry for the Secondary Side Connector | 11 |
| Description of Secondary Side Interface | 11 |
| General..... | 11 |
| DC/DC output (Vx+, Vx-) and COM x terminals | 12 |
| Reference terminal (RC x) | 12 |
| Collector sense (VCE x) | 12 |
| Gate terminals Gate x | 13 |
| Sense input (Sense x) | 13 |
| External fault input E.x..... | 13 |
| How Do 2SD300C17 SCALE-2 Drivers Work in Detail? | 14 |
| Power supply and electrical isolation | 14 |
| Power-supply monitoring..... | 14 |
| Vce monitoring / short-circuit protection | 15 |
| Blocking time | 15 |
| Bibliography | 15 |
| The Information Source: SCALE-2 Driver Data Sheets | 16 |
| Quite Special: Customized SCALE-2 Drivers | 16 |
| Technical Support | 16 |
| Quality | 16 |
| Legal Disclaimer | 16 |
| Ordering Information..... | 17 |
| Information about Other Products | 17 |
| Power Integrations Sales Offices..... | 18 |

Preliminary Description & Application Manual

Driver Overview

The 2SD300C17 is a driver core equipped with Power Integrations' latest SCALE-2 chipset /1/. The SCALE-2 chipset is a set of application-specific integrated circuits (ASICs) that cover the main range of functions needed to design intelligent gate drivers. The SCALE-2 driver chipset is a further development of the proven SCALE technology /2/.

The 2SD300C17 targets medium- and high-power IGBT applications such as windmill and solar converters, general purpose drives, as well as traction including parallel gate driving of IGBT modules. The 2SD300C17 comprises a complete dual-channel IGBT driver core, fully equipped with an isolated DC/DC converter, short-circuit protection, active clamping, soft turn-off and supply-voltage monitoring.

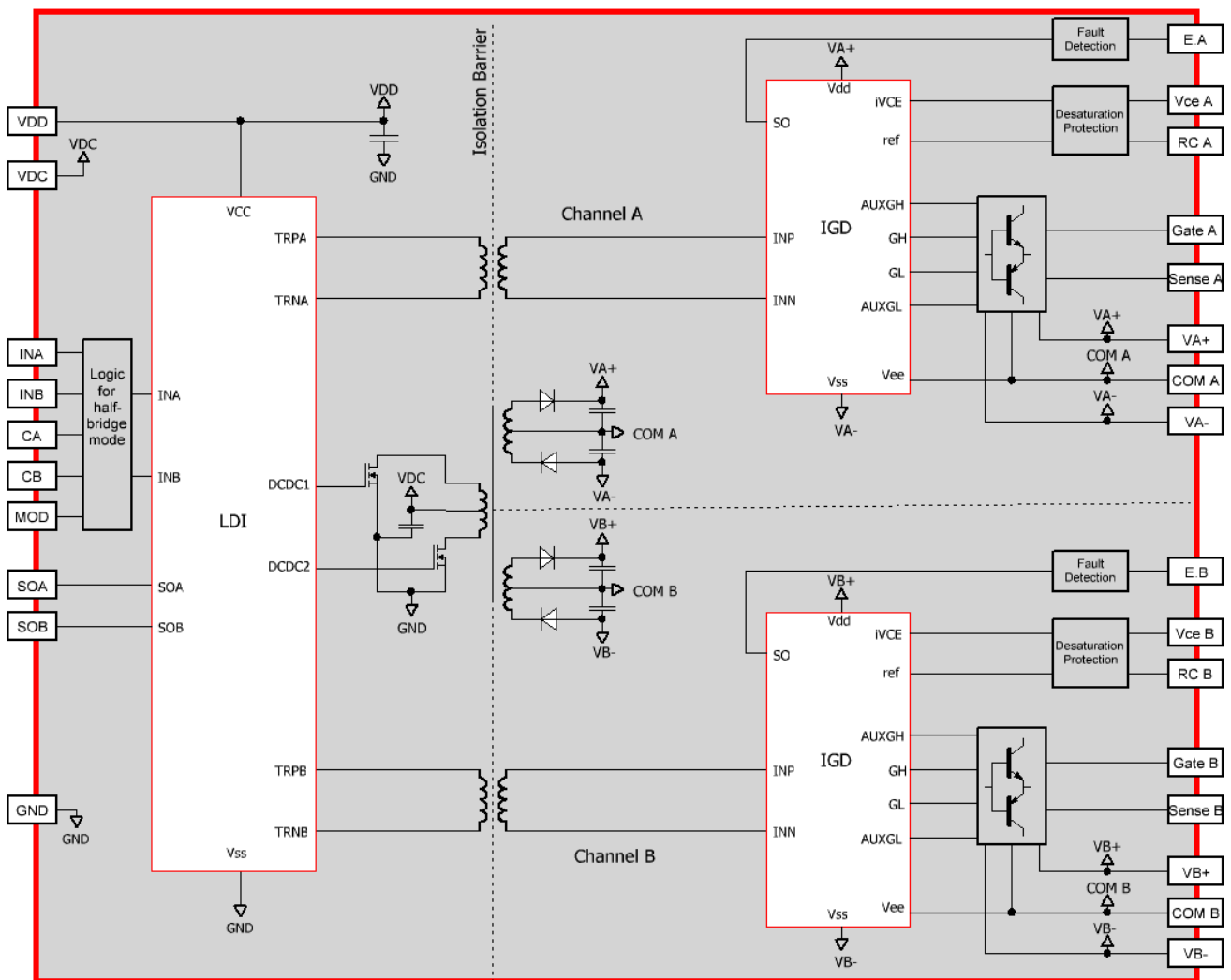

Fig. 2 Block diagram of the driver core 2SD300C17

Preliminary Description & Application Manual

Mechanical Dimensions

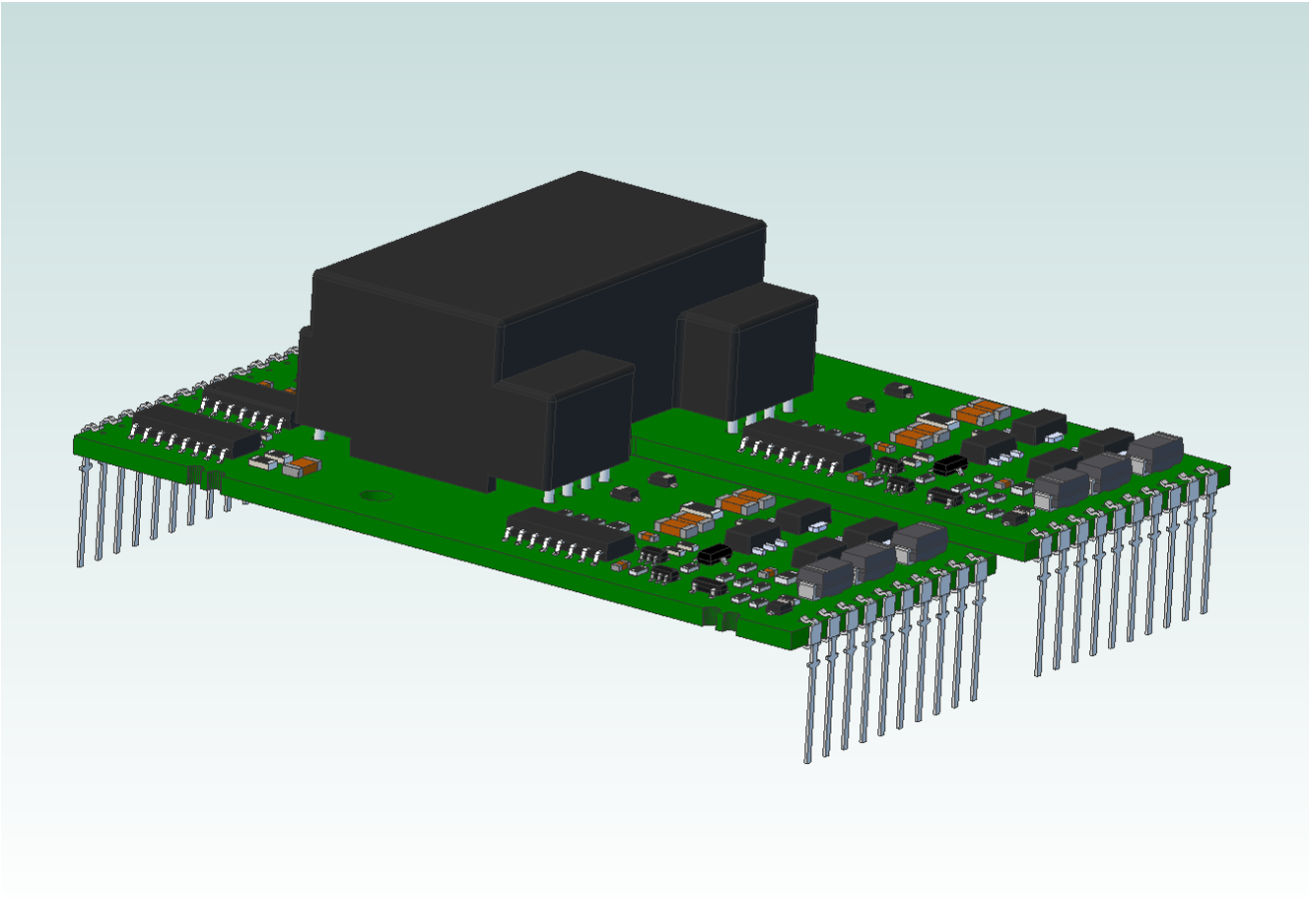

Fig. 3 Interactive 3D drawing of 2SD300C17

Preliminary Description & Application Manual

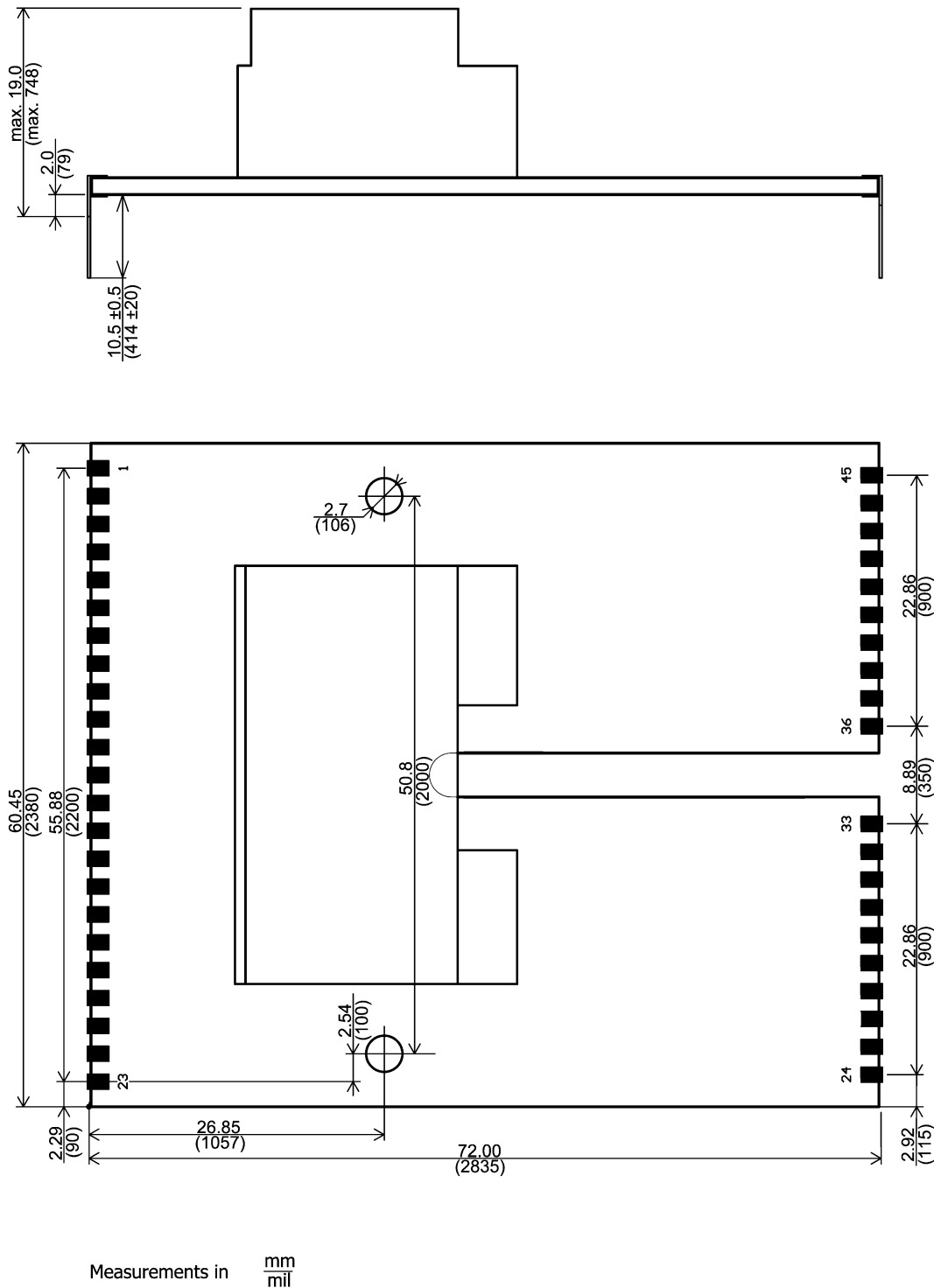

Fig. 4 Mechanical drawing (top view)

The primary side and secondary side pin grid is 2.54mm (100mil).

Total outline dimensions of the board are 60.5mm x 72mm. The total height of the driver is max. 19mm measured from the top layer of the host PCB to the top of the populated PCB on the driver.

Recommended diameter of solder pads: \varnothing 2mm (79mil)

Recommended diameter of drill holes: \varnothing 1mm (39mil)

Preliminary Description & Application Manual

Pin Designation

| Primary side | | | Secondary Sides | | |
|--------------|------|-----------------------------------|-----------------|---------|---------------------------------------|
| Pin | Name | Function | Pin | Name | Function |
| 1 | VDD | +15V for primary side electronics | 45 | Gate A | Gate channel A |
| 2 | VDD | +15V for primary side electronics | 44 | Gate A | Gate channel A |
| 3 | VDD | +15V for primary side electronics | 43 | COM A | Emitter A |
| 4 | SOA | Status output channel A | 42 | COM A | Emitter A |
| 5 | N.C. | Not connected | 41 | VA+ | +16V DC/DC output channel A |
| 6 | CA | Dead time channel A | 40 | VA- | -16V DC/DC output channel A |
| 7 | INB | Signal input channel B | 39 | Sense A | Soft turn-off / active clamping input |
| 8 | CB | Dead time channel B | 38 | RC A | Reference RC network channel A |
| 9 | Mod | Mode selection | 37 | Vce A | Collector sense channel A |
| 10 | SOB | Status output channel B | 36 | E.A | External fault input channel A |
| 11 | INA | Signal input channel A | 35 | Free | |
| 12 | GND | Ground | 34 | Free | |
| 13 | GND | Ground | 33 | Gate B | Gate channel B |
| 14 | VDC | DC/DC converter | 32 | Gate B | Gate channel B |
| 15 | VDC | DC/DC converter | 31 | COM B | Emitter B |
| 16 | VDC | DC/DC converter | 30 | COM B | Emitter B |
| 17 | VDC | DC/DC converter | 29 | VB+ | +16V DC/DC output channel B |
| 18 | VDC | DC/DC converter | 28 | VB- | -16V DC/DC output channel B |
| 19 | GND | Ground | 27 | Sense B | Soft turn-off / active clamping input |
| 20 | GND | Ground | 26 | RC B | Reference RC network channel B |
| 21 | GND | Ground | 25 | Vce B | Collector sense channel B |
| 22 | GND | Ground | 24 | E.B | External fault input channel B |
| 23 | GND | Ground | | | |

Note: Pins with the designation "Free" are not physically present

Preliminary Description & Application Manual

Recommended Interface Circuitry for the Primary Side Connector

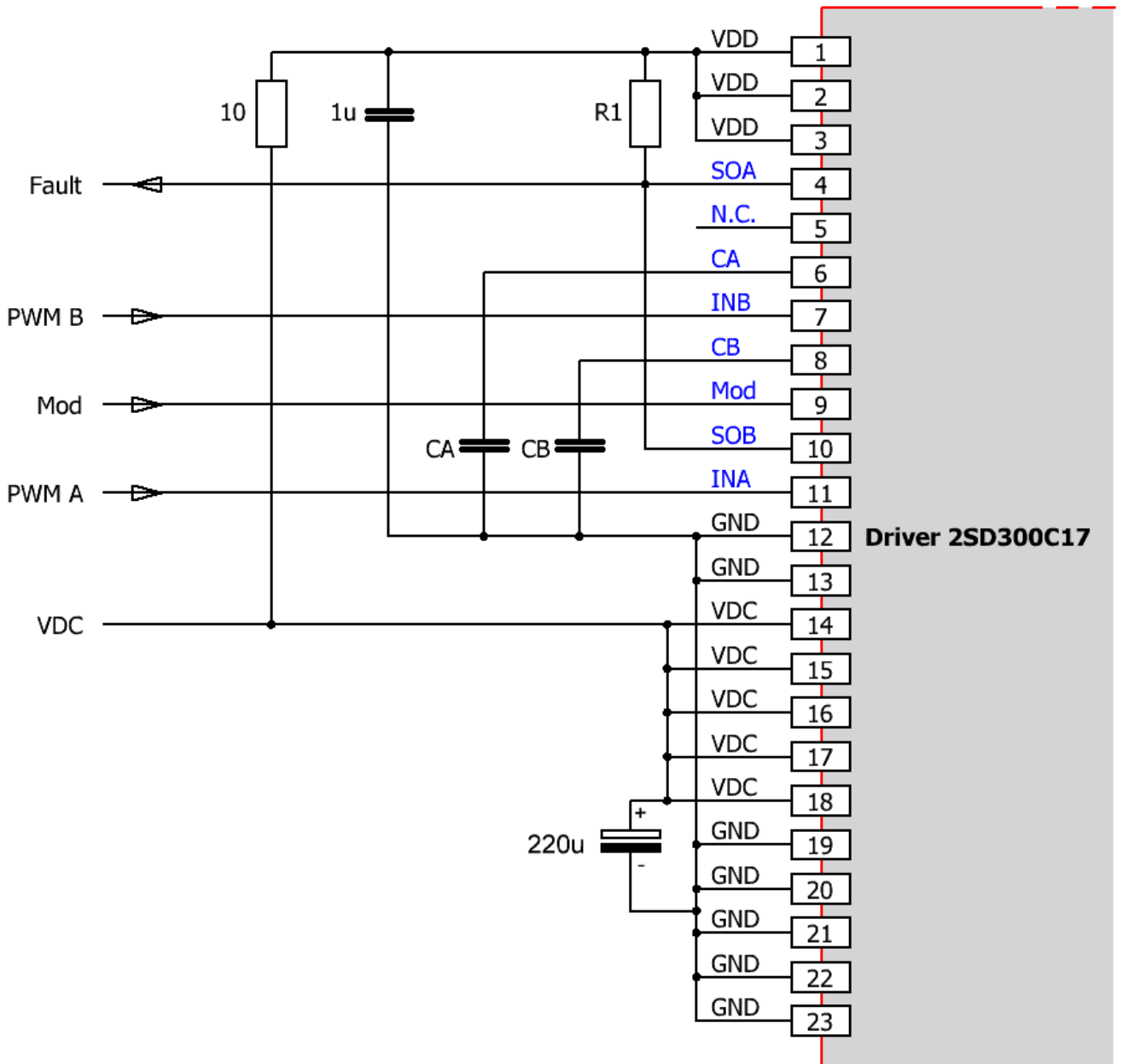

Fig. 5 Recommended user interface of 2SD300C17 (primary side)

All ground pins must be connected together with low parasitic inductance. A common ground plane or wide tracks are strongly recommended. The connecting distance between ground pins must be kept at a minimum.

Preliminary Description & Application Manual

Description of Primary Side Interface

General

The primary side interface of the driver 2SD300C17 is very simple and easy to use.

The driver primary side is equipped with a 23-pin interface connector with the following terminals:

- 8 x power-supply terminals
- 2 x drive signal inputs
- 2 x status outputs (fault returns)
- 1 x mode selection (half-bridge mode / direct mode)
- 2 x inputs to set the dead time (half-bridge mode)
- 1 x not connected (N.C.)

All inputs and outputs are ESD-protected. Moreover, all digital inputs have Schmitt-trigger characteristics.

VDC terminal

The driver has 5 VDC terminals on the interface connector to supply the DC-DC converter for the secondary sides. VDC should be supplied with a stabilized +15V power supply.

It is recommended to use a stabilizing capacitor of 220µF between VDC and GND.

VDD terminal

The driver has 3 VDD terminals on the interface connector to supply the primary side electronics with 15V.

It is recommended to connect the VDD terminals to VDC via a 10Ω resistor. An additional stabilizing capacitor of 1µF should be placed between VDD and GND.

It is also possible to run VDC and VDD directly in parallel without a 10Ω resistor.

Mod (mode selection)

The Mod input allows the operating mode to be selected.

Direct mode

If the Mod input is connected to GND, direct mode is selected. In this mode, there is no interdependence between the two channels. Input INA directly influences channel A while INB influences channel B. High level at an input (INA or INB) always results in turn-on of the corresponding IGBT. This mode should be selected only when the dead times are generated by the control circuitry so that each IGBT receives its own drive signal.

Caution: Synchronous or overlapping timing of both switches of a half-bridge basically shorts the DC link.

Preliminary Description & Application Manual

Half-bridge mode

If the Mod input is connected to VDD, half-bridge mode is selected. In this mode, the input INA influences channel A while INB influences channel B. However, only one channel can be turned-on at a given time and a defined dead time (interlock time) between both channels is generated (Fig. 6). The dead time between both channels can be adjusted with the input pins CA and CB (see "CA and CB (input for adjusting the dead time in half-bridge mode)" on page 10). If both signals INA/INB are high, both gate signals are low (-15V).

The following Fig. 6 shows the driver behavior in half-bridge mode.

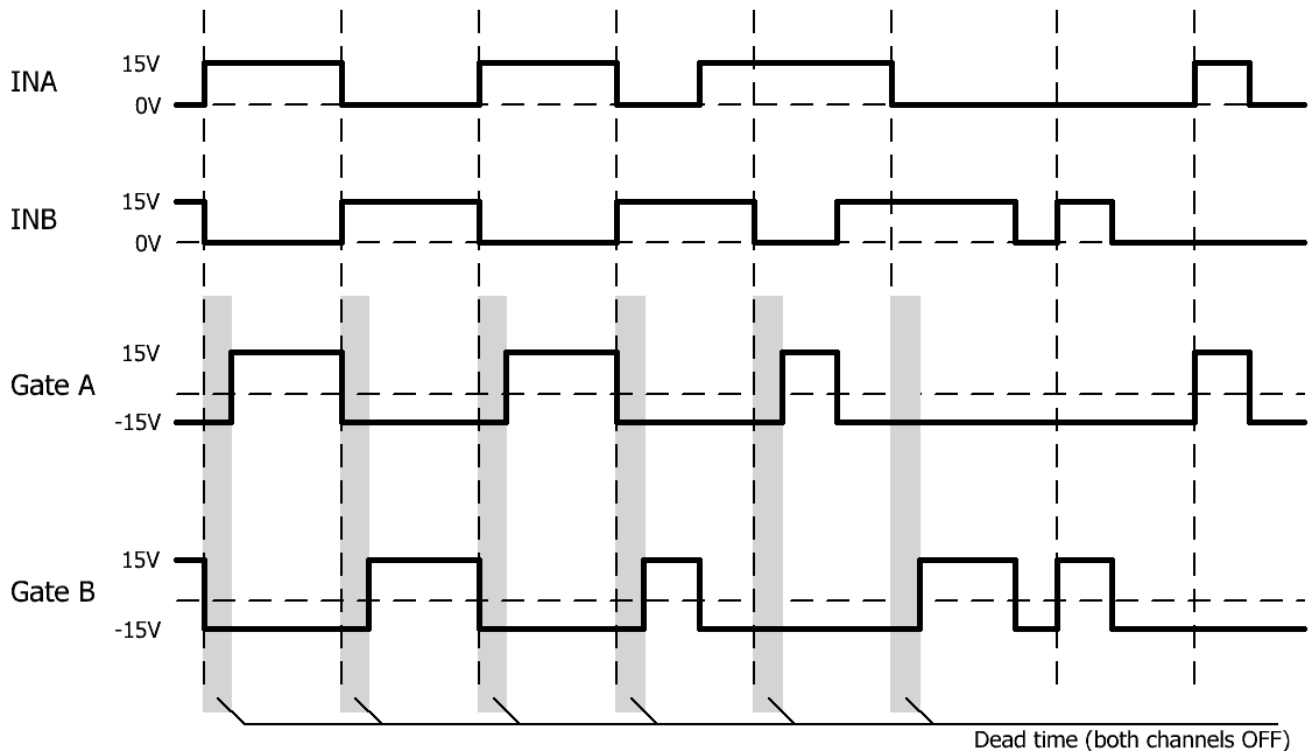

Fig. 6 Signals in half-bridge mode

INA, INB (channel drive inputs, e.g. PWM)

INA and INB are basically drive inputs, but their function depends on the Mod input (see above).

15V logic-level signals should be applied at INA and INB.

No pulse shorter than 1.5 μ s should be applied to the driver inputs. A pulse shorter than 1.5 μ s could occasionally activate the soft turn-off function of the driver.

SOA, SOB (status outputs)

The outputs SOx have open-drain transistors. When a fault condition is detected in channel "x", the status output SOx goes to low (connected to GND). Otherwise, the output has high impedance.

Both SOx outputs are not connected to a single signal on the driver. They can be connected together to provide a common fault signal (e.g. for one phase) if required.

The maximum SOx current in a fault condition should not exceed the value specified in the driver data sheet /3/.

Preliminary Description & Application Manual

How the status information is processed

- a) A fault on the secondary side (detection of short-circuit of IGBT module, supply undervoltage or external fault input) is transmitted to the corresponding SOx output immediately. The corresponding SOx output is automatically reset (returning to a high impedance state) after the blocking time has elapsed (refer to the driver data sheet for timing information /3/).
- b) A supply undervoltage on the primary side is indicated to both SOx outputs at the same time. Both SOx outputs are automatically reset (returning to a high impedance state) when the undervoltage on the primary side disappears (refer to the driver data sheet for timing information /3/).

Note that no external reset input is available on the driver. The driver is automatically reset after the blocking time has elapsed.

CA and CB (input for adjusting the dead time in half-bridge mode)

Terminals CA and CB allow the generated dead time between both channels A and B to be determined in half-bridge mode. The dead time can be defined with a capacitor placed between pins CA and CB and GND (Fig. 5).

The following table 1 shows the dead time as a function of the capacitance of CA and CB:

| Capacitance of CA and CB | Dead time |
|--------------------------|-----------|
| 0pF | 1.3μs |
| 47pF | 1.7μs |
| 100pF | 2.1μs |
| 220pF | 3.0μs |
| 330pF | 3.8μs |
| 470pF | 4.8μs |
| 1nF | 8.8μs |

Table 1 Generated dead time as a function of CA and CB in half-bridge mode

In direct mode, it is recommended to connect the inputs CA and CB with a 470pF capacitor to GND. CA or CB must not be connected to any external potential (e.g. GND or VDD).

Preliminary Description & Application Manual

Recommended Interface Circuitry for the Secondary Side Connector

Fig. 7 shows the recommended interface circuit for the secondary side of the driver (channel A). The same circuit can be used for channel B (not shown).

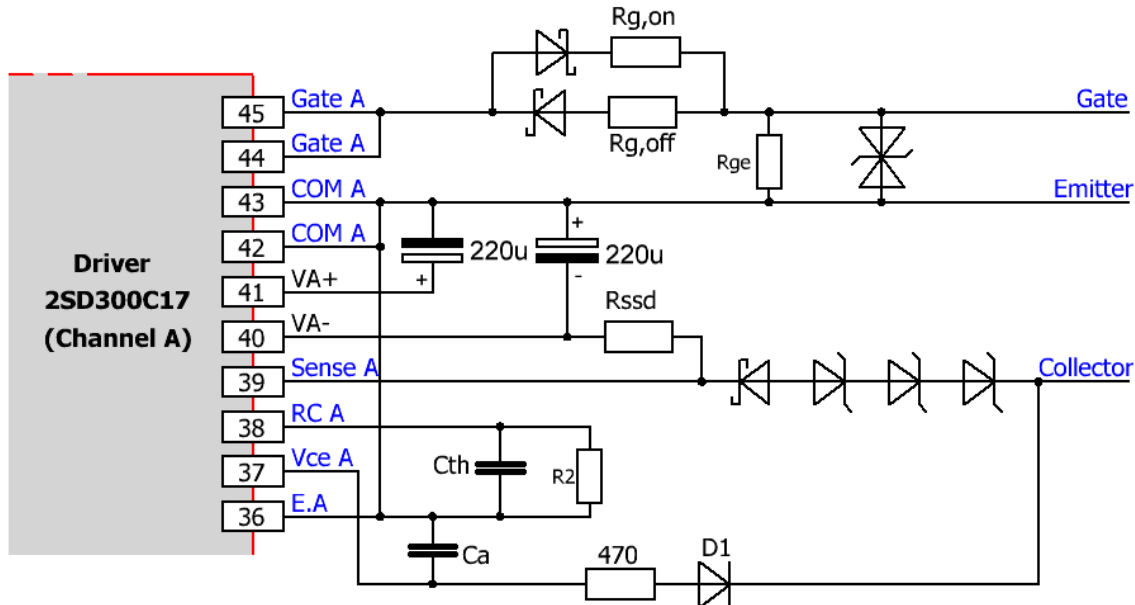

Fig. 7 Recommended user interface of 2SD300C17 (only channel A, secondary side)

Description of Secondary Side Interface

General

The driver's secondary sides are each equipped with a 10-pin interface connector with the following terminals (x stands for A or B):

- 2 x DC/DC output terminals (Vx+ and Vx-)
- 2 x emitter terminals COM x
- 1 x reference terminal RC x for overcurrent or short-circuit protection
- 1 x collector sense terminal VCE x
- 2 x gate terminals Gate x
- 1 x sense terminal for active clamping and/or soft-turn-off Sense x
- 1 x external fault input E.x

All inputs and outputs are ESD-protected.

Preliminary Description & Application Manual

DC/DC output (Vx+, Vx-) and COM x terminals

The driver is equipped with blocking capacitors on the secondary side of the DC/DC converter (for values, refer to the data sheet /3/). It is recommended to use additional external blocking capacitors of 220µF to reduce the dynamic voltage drop due to high pulse currents.

The blocking capacitors must be placed between Vx+ and COM x as well as between COM x and Vx- (Fig. 7). They must be connected as close as possible to the driver's terminal pins with minimum inductance. Capacitors with high ripple current capability should be used.

Reference terminal (RC x)

The reference terminal RC x allows the threshold to be set for short-circuit and/or overcurrent protection with a resistor Rth placed between RC x and COM x. Moreover, instead of a static reference, a dynamic reference is used to check the collector-emitter voltage of the IGBT at turn-on. The time constant of the dynamic reference can be set with a capacitor Cth placed between RC x and COM x. It allows the short-circuit duration to be adjusted in case of IGBT short-circuit.

The following table 2 shows the static reference as well as the short-circuit duration (short-circuit type I) according to IEC 60747-9 for different values of Rth and Cth. The short-circuit duration was measured under the following conditions:

- IGBT module: FF1000R17IE4 from Infineon
- $R_{g,on}=1.2\Omega$ and $R_{g,off}=1.8\Omega$
- $R_{ssd}=10k\Omega$, $C_a=1nF$ (Fig. 7)
- DC-link voltage: 1000V

| Resistance Rth | Threshold | Short-circuit duration | | | | |
|----------------|-----------|------------------------|-----------|-----------|-----------|---------|
| | | Cth=0pF | Cth=100pF | Cth=220pF | Cth=470pF | Cth=1nF |
| 2kΩ | 1.9V | 2µs | 2.1µs | 2.3µs | 2.7µs | 3.6µs |
| 5.4kΩ | 3.9V | 2.2µs | 2.6µs | 3.1µs | 3.9µs | 5.6µs |
| 12kΩ | 5.8V | 2.5µs | 3.5µs | 4.2µs | 5.5µs | 7.6µs |
| 32kΩ | 7.8V | 3.7µs | 4.9µs | 5.9µs | 7.4µs | 10µs |
| 70kΩ | 8.8V | 5.1µs | 6µs | 7µs | 8.6 µs | 11.7µs |

Table 2 Dynamic threshold voltage for overcurrent and/or short-circuit protection

Note that the short-circuit duration is dependent on the IGBT module used and the gate resistors. It is therefore recommended to measure it in the final application. The short-circuit duration should not exceed the maximum value given in the IGBT module data sheet.

Collector sense (VCE x)

2SD300C17 drivers are equipped with a dynamic collector sense function. The collector sense must be connected to the IGBT collector with the circuit shown in Fig. 7 in order to detect an IGBT overcurrent or short-circuit. For more details about the functionality of this feature, refer to "Vce monitoring / short-circuit protection" on page 15.

Preliminary Description & Application Manual

Gate terminals Gate x

These terminals allow the turn-on and turn-off gate resistors to be connected to the gate of the power semiconductor. Please refer to the driver data sheet /3/ for the limit values of the gate resistors used.

The auxiliary emitter of the IGBT must be connected directly to the COM x terminals of the driver.

A resistor R_{ge} of 10k Ω between Gate x and COM x is recommended in order to provide a low-impedance path from the IGBT gate to the emitter even if the driver is not supplied with power. Moreover, gate clamping should be realized with a zener diode between Gate x and COM x.

Note however that it is not advisable to operate the power semiconductors within a half-bridge with a driver in the event of a low supply voltage. Otherwise, a high rate of increase of V_{ce} may cause partial turn-on of these IGBTs.

Sense input (Sense x)

The Sense x inputs can be used:

- to adjust the soft turn-off behavior
- to activate active clamping.

Both techniques allow the IGBT to be protected against collector-emitter overvoltages in case of overcurrent and/or short-circuit turn-off. Note that soft turn-off does not offer 100% protection against turn-off overvoltages. If the pulse duration determined by the corresponding input INx is shorter than the driver response time (time between gate-emitter turn-on and short-circuit detection), the driver will switch off the short-circuit without the soft turn-off function. In this case, active clamping can be used to limit the turn-off overvoltage.

A typical value of $R_{ssd}=10k\Omega$ is recommended. If necessary, this value can be modified in order to adjust the soft turn-off behavior of the driver.

Active clamping can be realized with a feedback from the collector to the Sense x input according to Fig. 7. It is recommended to use the following transient voltage suppressors (TVS):

- 1x440V TVS (or 2x220V TVS) with 600V IGBTs with DC-link voltages up to 400V
 - 2x440V TVS (or 4x220V TVS) with 1200V IGBTs with DC-link voltages up to 800V and
 - 3x440V TVS (or 6x220V TVS) with 1700V IGBTs with DC-link voltages up to 1200V
-

External fault input E.x

The 2SD300C17 is equipped with an external fault input on each driver channel. This allows a fault to be generated on the corresponding channel. The external fault is handled in the same way as an overcurrent/short-circuit or supply undervoltage fault.

If the external fault input E.x is not used, it must be connected to COM x.

If it is used, the following conditions must be met in order to ensure proper function of the driver:

- The slew rate of E.x should be higher than 0.1V/ μ s
 - The pulse width applied to E.x must be longer than 1 μ s
 - As soon as one channel is in a fault condition (SOx output goes to low), the other channel must be switched off (it is not switched off by the driver)
 - The dead time between both channels must be higher than 2 μ s + reaction time of the host system (time between fault feedback SOx of the driver and turn-off command for the other channel)
-

Preliminary Description & Application Manual

How Do 2SD300C17 SCALE-2 Drivers Work in Detail?

Power supply and electrical isolation

The driver is equipped with a DC/DC converter to provide an electrically insulated power supply to the gate driver circuitry. All transformers (DC/DC and signal transformers) feature safe isolation to EN 50178, protection class II between the primary side and either secondary side.

Note that the driver requires a stabilized supply voltage.

Power-supply monitoring

The driver's primary side as well as both secondary-side driver channels are equipped with a local undervoltage monitoring circuit.

In case of a primary-side supply undervoltage, both IGBTs are driven with a negative gate voltage to keep them in the off-state (both channels are blocked) and the fault is transmitted to both outputs SOA and SOB until the fault disappears.

In case of a secondary-side supply undervoltage, the corresponding IGBT is driven with a negative gate voltage to keep it in the off-state (the channel is blocked) and a fault condition is transmitted to the corresponding SOx output. The SOx output is automatically reset (returning to a high impedance state) after the blocking time.

Preliminary Description & Application Manual

Vce monitoring / short-circuit protection

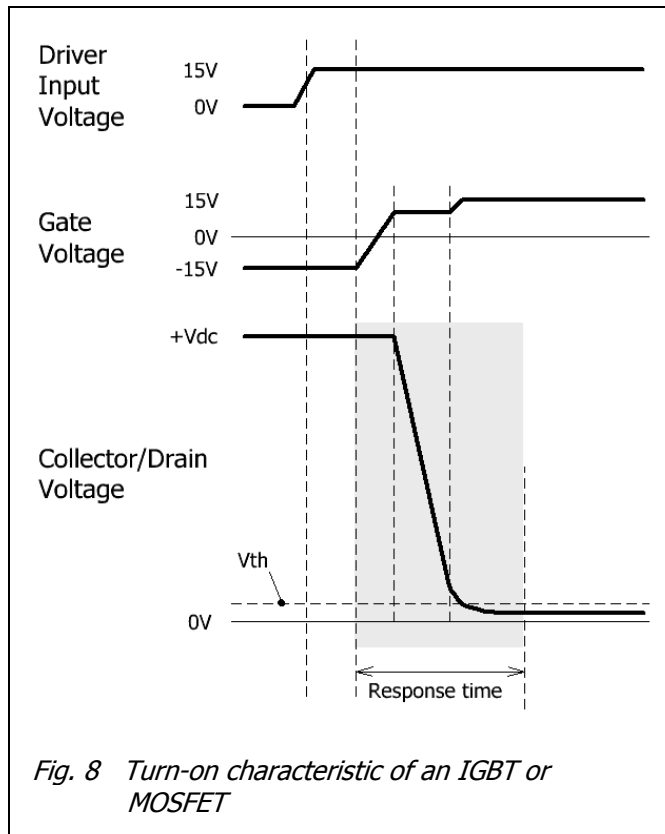

The 2SD300C17 driver is equipped with a Vce monitoring circuit. The recommended circuit is illustrated in Fig. 7. A resistor and a capacitor (Rth and Cth in Fig. 7) are used as the reference elements for defining the dynamic turn-off threshold.

It is recommended to use a value of $C_a=1\text{nF}$ and fast diodes such as UF4007 (2 diodes for 1200V or 1700V IGBTs) for D1.

During the response time, the Vce monitoring circuit is inactive. The response time is the time that elapses after turn-on of the power semiconductor until the collector/drain voltage is measured (Fig. 8).

Vce is checked after the response time at turn-on to detect a short circuit or overcurrent. If this voltage is higher than the programmed threshold V_{th} , the driver detects a short circuit or overcurrent, switches the power semiconductor off and signals the fault immediately to the corresponding SOx output. The power semiconductor is kept off (non-conducting) and the fault is shown at pin SOx as long as the blocking time is active.

Note that only the channel with a Vce monitoring fault (short-circuit or overcurrent) is turned-off and blocked until the blocking time has elapsed.

Blocking time

In case of a secondary side fault (short-circuit or overcurrent, supply undervoltage, external fault input), the fault is immediately transmitted to the primary side and shown at the corresponding output SOx. The corresponding channel is blocked during the blocking time (for timing information, refer to the driver data sheet). After the blocking time, the driver channel is automatically reset and the fault at the corresponding SOx output disappears.

Note that the other channel (channel without fault) is not turned off and no fault is generated at the corresponding SOx output.

Bibliography

- /1/ "Smart Power Chip Tuning", Bodo's Power Systems, May 2007
- /2/ "Description and Application Manual for SCALE Drivers", Power Integrations
- /3/ Data sheet SCALE-2 driver core 2SD300C17, Power Integrations

Note: These papers are available on the Internet at www.power.com/igbt-driver/go/papers

Preliminary Description & Application Manual

The Information Source: SCALE-2 Driver Data Sheets

Power Integrations offers the widest selection of gate drivers for power MOSFETs and IGBTs for almost any application requirements. The largest website on gate-drive circuitry anywhere contains all data sheets, application notes and manuals, technical information and support sections: www.power.com.

Quite Special: Customized SCALE-2 Drivers

If you need an IGBT driver that is not included in the delivery range, please don't hesitate to contact Power Integrations or your Power Integrations sales partner.

Power Integrations has more than 25 years experience in the development and manufacture of intelligent gate drivers for power MOSFETs and IGBTs and has already implemented a large number of customized solutions.

Technical Support

Power Integrations provides expert help with your questions and problems:

www.power.com/igbt-driver/go/support

Quality

The obligation to high quality is one of the central features laid down in the mission statement of Power Integrations Switzerland GmbH. Our total quality management system assures state-of-the-art processes throughout all functions of the company, certified by ISO9001:2008 standards.

Legal Disclaimer

The statements, technical information and recommendations contained herein are believed to be accurate as of the date hereof. All parameters, numbers, values and other technical data included in the technical information were calculated and determined to our best knowledge in accordance with the relevant technical norms (if any). They may base on assumptions or operational conditions that do not necessarily apply in general. We exclude any representation or warranty, express or implied, in relation to the accuracy or completeness of the statements, technical information and recommendations contained herein. No responsibility is accepted for the accuracy or sufficiency of any of the statements, technical information, recommendations or opinions communicated and any liability for any direct, indirect or consequential loss or damage suffered by any person arising therefrom is expressly disclaimed.

Preliminary Description & Application Manual

Ordering Information

Our international terms and conditions of sale apply.

| Type Designation | Description |
|------------------|---|
| 2SD300C17A1 | Dual-channel SCALE-2 driver core (PCB thickness: 1.55mm) |
| 2SD300C17A2 | Dual-channel SCALE-2 driver core (PCB thickness: 1.55mm, lead free) |
| 2SD300C17A3 | Dual-channel SCALE-2 driver core (PCB thickness: 1.55mm, increased EMI capability, lead free) |

Product home page: www.power.com/igbt-driver/go/2SD300C17

Information about Other Products

For other driver cores:

Direct link: www.power.com/igbt-driver/go/cores

For other drivers, product documentation, evaluation systems and application support

Please click onto: www.power.com

Preliminary Description & Application Manual

Power Integrations Sales Offices

WORLD HEADQUARTERS

5245 Hellyer Avenue
San Jose, CA 95138 USA
Tel: +1-408-414-9200
Fax: +1-408-414-9765
Email: usasales@power.com

AMERICAS WEST

5245 Hellyer Avenue
San Jose, CA 95138 USA
Tel: +1-408-414-8778
Fax: +1-408-414-3760
Email: usasales@power.com

GERMANY (AC-DC/LED Sales)

Lindwurmstrasse 114
80337 München, Germany
Tel: +49-89-5527-39100
Fax: +49-89-1228-5374
Email: eurosales@power.com

INDIA (Mumbai)

Unit: 106-107, Sagar Tech Plaza-B
Sakinaka, Andheri Kurla Road
Mumbai, Maharashtra 400072 India
Tel 1: +91-22-4003-3700
Tel 2: +91-22-4003-3600
Email: indiasales@power.com

JAPAN

Kosei Dai-3 Bldg.
2-12-11, Shin-Yokohama, Kohoku-ku
Yokohama-shi, Kanagawa
Japan 222-0033
Tel: +81-45-471-1021
Fax: +81-45-471-3717
Email: japansales@power.com

TAIWAN

5F, No. 318, Nei Hu Rd., Sec. 1
Nei Hu Dist.
Taipei, 114 Taiwan
Tel: +886-2-2659-4570
Fax: +886-2-2659-4550
Email: taiwansales@power.com

AMERICAS EAST

7360 McGinnis Ferry Road
Suite 225
Suwanee, GA 30024 USA
Tel: +1-678-957-0724
Fax: +1-678-957-0784
Email: usasales@power.com

CHINA (Shanghai)

Room 2410, Charity Plaza
No. 88 North Caoxi Road
Shanghai, 200030 China
Tel: +86-21-6354-6323
Fax: +86-21-6354-6325
Email: chinasales@power.com

GERMANY (IGBT Driver Sales)

HellwegForum 1
59469 Ense, Germany
Tel: +49-2938-64-39990
Email: igbt-driver.sales@power.com

INDIA (New Dehli)

#45, Top Floor
Okhla Industrial Area, Phase - III
New Dehli, 110020 India
Tel 1: +91-11-4055-2351
Tel 2: +91-11-4055-2353
Email: indiasales@power.com

KOREA

RM602, 6FL, 22
Teheran-ro 87-gil, Gangnam-gu
Seoul, 06164 Korea
Tel: +82-2-2016-6610
Fax: +82-2-2016-6630
Email: koreasales@power.com

UNITED KINGDOM

Bulding 5, Suite 21
The Westbrook Centre
Milton Road
Cambridge, CB4 1YG United Kingdom
Tel: +44-7823-557-484
Email: eurosales@power.com

AMERICAS CENTRAL

333 Sheridan Road
Winnetka, IL 60093 USA
Tel: +1-847-721-6293
Email: usasales@power.com

CHINA (Shenzhen)

17/F, Hivac Building, No 2
Keji South 8th Road, Nanshan District
Shenzhen, 518057 China
Tel: +86-755-8672-8689
Fax: +86-755-8672-8690
Email: chinasales@power.com

INDIA (Bangalore)

#1, 14th Main Road
Vasanthangar
Bangalore, 560052 India
Tel 1: +91-80-4113-8020
Tel 2: +91-80-4113-8028
Fax: +91-80-4113-8023
Email: indiasales@power.com

ITALY

Via Milanese 20
20099 Sesto San Giovanni (MI), Italy
Tel: +39-02-4550-8708
Email: eurosales@power.com

SINGAPORE

51 Newton Road
#19-01/05 Goldhill Plaza
Singapore, 308900
Tel 1: +65-6358-2160
Tel 2: +65-6358-4480
Fax: +65-6358-2015
Email: singaporesales@power.com