

LED Driver Basics and Its Circuit Design

Author: Apogeeweb

Date: 9 Apr 2018

15440

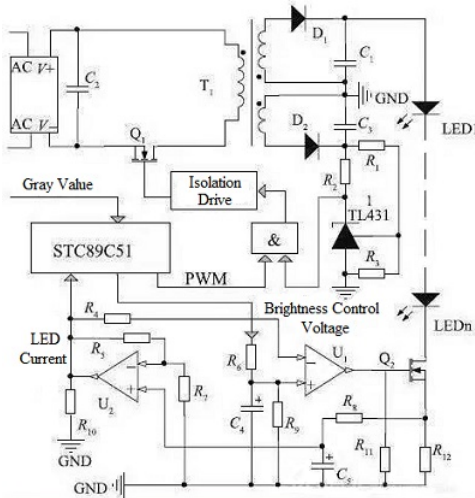

Warm hints: The word in this article is about **3800** words and reading time is about **23** minutes.

Introduction

LED is recognized as the fourth generation of green light source. It is a solid cold light source. It has many advantages, such as high efficiency, long life, safe and environmental protection, small size, high reliability, fast response speed and so on. At present, the same lighting effect is achieved. The power consumption of LED is about 1/10 of incandescent lamp and 1/2 of fluorescent lamp. Many countries and regions have introduced a variety of policies to support the development of the LED industry, so that the industry can become an important part of the country's important industries, giving birth to huge business opportunities. LED driver circuit is very important for LED, while LED dimming control can save energy. The driving and dimming of high brightness white LED are hot topics in recent years.



I LED Driver Basics

1.1 What is a LED Driver

1.2 Characteristics of LED Driver Power Supply

II Types of LED driver

2.1 LED Driver Constant Current

2.2 LED Driver Constant Voltage

III The Application of LED Driver

IV LED Driver Common Use Product Example Diagram

V Led Driver Circuit Basics

5.1 What is LED Driver Circuit

5.2 Types of LED Driver Circuit and Its Classification

VI Novel Driver Circuit Design

VII Basic Suggestion for Designing LED Driver

7.1 LED Current Size

7.2 Chip Fever

7.3 Power Tube Fever

7.4 Frequency Reduction of Working Frequency

7.5 The Selection of Inductors or Transformers

VIII Conclusion

I LED Driver Basics

1.1 What is a LED Driver

Led driver changes the power supply to a specific voltage current to drive the LED voltage converter. In general, the input of the LED driver includes the high voltage power frequency AC (i.e., the city electricity), the low voltage DC, the high voltage DC, the low voltage and high frequency AC (such as the output of the electronic transformer). The output of LED driver power is mostly a constant current source that can change voltage with the change of LED forward voltage drop. The core components of LED power supply include switch controller, inductor, switch component (MOSFET), feedback resistor, input filter device, output filter and so on. According to the requirements of different occasions, there must be input over-voltage protection circuit, input under-voltage protection circuit, LED open circuit protection, over-current protection circuit and so on.

1.2 Characteristics of LED Driver Power Supply

- > (1) high reliability

Especially the driving power of LED street lamp is installed at high altitude, so the maintenance is not convenient, and the cost of maintenance is also large.

- > (2) high efficiency

LED is an energy-saving product, and the efficiency of driving power is high. It is very important for the power to be installed in the luminaire. The efficiency of the power supply is high, its power consumption is small, the heat in the luminaire is small, and the temperature rise of the lamp is also reduced. Favorable to delay the LED attenuation.

- > (3) high power factors

The power factor is the demand of the power grid for the load. Generally, there are no mandatory indicators for electrical appliances below 70 watts. Although the power factor of single electric appliance is low, it has little influence on the power grid, but in the evening, the power of the power grid will be seriously polluted by the large amount of lighting and the concentration of the same kind of load. For the 30 watts ~40 watts LED driver, it is said that in the near future, there may be some index requirements for power factor.

- > (4) driving mode

Now there are two kinds of traffic: one is a constant voltage source for multiple constant current sources, and each constant current source is supplied to each LED individually. In this way, the combination is flexible, and all the LED failures do not affect the work of other LED, but the cost will be slightly higher. The other is direct constant current power supply, that is, the drive mode of "Keke Hui Bao", which is driven by LED in series or parallel operation. It has the advantage of low cost, but poor flexibility, but also to solve a LED failure, does not affect other LED operation problems. The two forms coexist in a period of time. The way of multi way constant current output power will be better in terms of cost and performance. Maybe it's the main direction in the future.

- > (5) surge protection

The ability of LED to resist surge is relatively poor, especially the ability to resist reverse voltage. It is also important to strengthen the protection in this area. Some LED lights are outdoors, such as LED street lights. Because of the load shedding and lightning induction, all kinds of surge will be invaded from the power grid, and some surges will cause LED damage. Therefore, the analysis of the driving power of "Zhongke Hui Bao" should be deficient in surge protection. As for the frequent replacement of power and lamps, the LED driver should have the ability to suppress the surge and protect the LED from being damaged.

- > (6) protection function

In addition to the conventional protection, it is best to increase the LED temperature negative feedback in the constant current output, to prevent the high temperature of LED; to meet the requirements of safety and electromagnetic compatibility.



II Types of LED Driver

2.1 LED Driver Constant Current

The common market led lamp driver is divided into two kinds according to the driving mode. One is constant current drive. The characteristic of constant current drive is that the output current is constant. The output voltage is changed in one range. So we often see that the driving shell is marked out (output: DC**V - **V * ** mA \pm 5%) in the market. This means that the output voltage is in one of the output voltages. The range, the current is how many ma.

- A. The output current of the constant current drive circuit is constant, but the output DC voltage varies in a certain range with the different size of the load. The load resistance is small, the output voltage is low, the greater the load resistance is, the higher the output voltage is.
- B.Constant current circuit is not afraid of load short circuit, but it is strictly forbidden to load fully open.
- C.The constant current drive circuit is ideal for driving LED, but relatively speaking, the price is higher.
- D.Attention should be paid to the maximum withstand current and voltage used, which limits the number of LED used.

2.2 LED Driver Constant Voltage

And the other is the constant voltage drive. The characteristic of the constant voltage driving is that the output voltage is fixed, the current is within the maximum value with the change of the lamps and lanterns. In the case, the shell usually indicates (output:DC**V **A) is the voltage of the output fixed volt, the maximum output current is how many.Led market common is the output 5V, 12V, 24V and so on.

- A.When the parameters in the voltage stabilizing circuit are determined, the output voltage is fixed, while the output current changes with the increase or decrease of the load.

- B.The voltage stabilizing circuit is not afraid of load opening, but it is strictly forbidden to load short circuit completely.
- C.The LED is driven by a regulated drive circuit. Each string needs a proper resistor to make the average brightness of each string LED average.
- D.The brightness will be affected by the voltage changes that are rectified.

III The Application of LED Driver

The application of LED driver depends on the LED parameters we want to drive. The most important two parameters are the input voltage and the input current. How to calculate the input voltage and current of the LED lamp, the propagation lamp is equipped with a separate explanation. Here is only a description of the input of the LED lamp. People will see the original driving parameters (be sure to identify some driving false targets!!!!

After knowing the input voltage and input current of the lamp board, we choose the corresponding LED driver to use. For example, it is known that the input voltage of the lamp board is 37-40V, the input current is 300mA, then the LED driver output voltage can be selected to include it, the current is about the same. The formula surface, the voltage higher or lower than all, must be included. Otherwise, there will be flickering. Low current is fine.



Finally, we only need to press the positive and negative pole marked by the lamp plate to weld the drive or connection line. It is necessary to note that the conventional LED driven output line, the red is the positive pole. The black is the negative pole... If it is gray line, then the gray is the positive pole, the white is the negative... Blue brown line, the blue line is the negative pole, the blue line is the negative pole and so on...

IV LED Driver Common Use Product Example Diagram

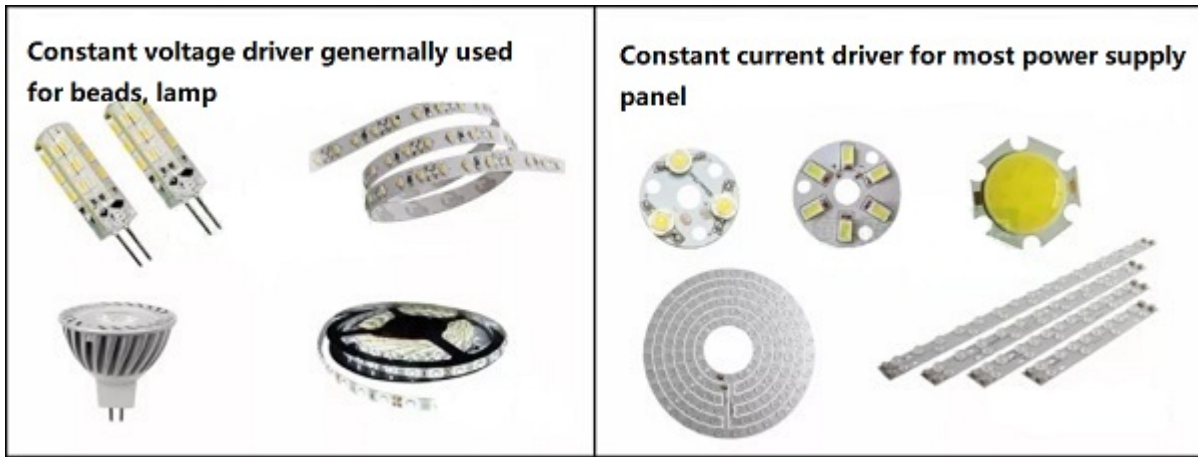
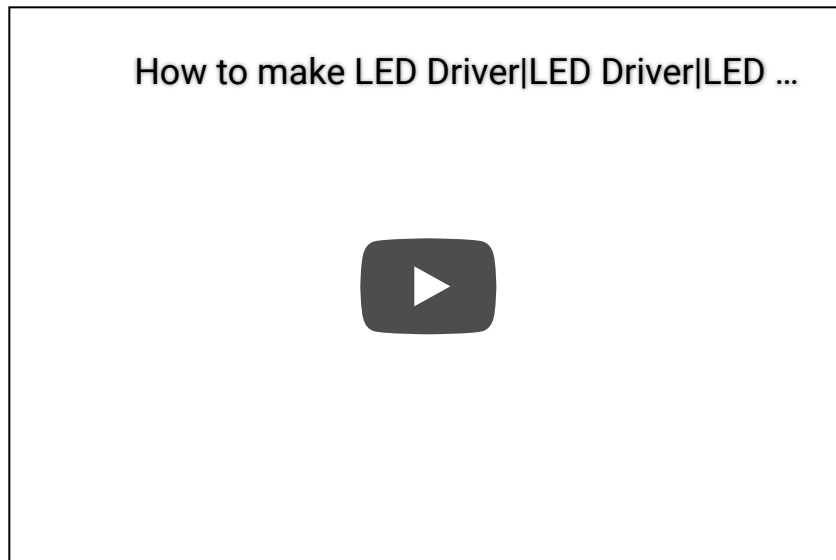

Figure 1. LED Driver Common Use Product Example Diagram

Let's see an video about how to make LED driver:



How to Make a LED driver

V Led Driver Circuit Basics

5.1 What is LED Driver Circuit

An LED driver is an electrical device which regulates the power to an LED or a string (or strings) of LEDs. An LED driver responds to the changing needs of the LED, or LED circuit, by providing a constant quantity of power to the LED as its electrical properties change with temperature.

5.2 Types of LED Driver Circuit and Its Classification

- A.Charge pump circuit

The charge pump circuit is also a DC/DC converter circuit. The charge pump circuit uses the capacitance to store the energy of the charge accumulation effect, and the capacitive energy coupling element, by controlling the power electronic device to switch the high frequency switch, in a period of time, the capacitor can be stored and the energy is released in the remaining time. This circuit obtains different output voltages through

different connections between capacitor charging and discharging, and the whole circuit does not need any inductors.

The charge pump circuit is relatively small, with less components and lower cost, but the switch element is relatively large, and the output voltage range is relatively small when the input voltage is certain, the output voltage is mostly 1/3~3 times of the input voltage, and the power rate of the circuit is small, and the efficiency will follow the output voltage and input. The relationship between voltage changes. Multiple LED must be driven in parallel. In order to prevent uneven current distribution, ballast resistors must be adopted, which will greatly reduce the efficiency of the system. Therefore, the charge pump driving circuit is limited in the application of high power LED lighting driver, and it is mostly used in the case of low power.

- B. Switch power circuit

The switching power supply circuit is a DC/DC transform circuit which changes the output voltage by changing the time ratio between switching and turn off. From the circuit point of view, compared with the charge pump circuit, it contains magnetic components, that is inductor or high frequency transformer. The switching power supply is divided into two types of DC/DC converters, namely, input and output without isolation, namely, "direct connection" and "input and output".

The typical circuits of "straight through" DC/DC converter include Buck, Boost, Buck-Boost and Cuk. The typical circuits of isolated DC/DC converters with input and output are single ended forward, single ended flyback, push-pull, half bridge and full bridge. The switching power supply circuit can achieve a wide range of voltage output, and the output voltage is adjustable continuously, the output power is large, so the application range is wider, especially in the medium and large power situations.

- C. Linear circuit

The linear control circuit regards the semiconductor power device working in the linear region as a dynamic resistor, and realizes constant current drive through its control level control. The disadvantage of linear control circuit is low efficiency, but it has a fast response to the change of input voltage and load. The circuit is relatively simple. It is easy to control the current of LED directly, and it is easy to control the high precision of the current.

VI Novel Driver Circuit Design

The actual feedback control of switching power supply is the output voltage, and the output current control is not easy to be accurate, and the LED lamp is easily damaged when the control of the switching power supply is biased; the efficiency of the linear circuit is not high.

Based on the above reasons, a novel LED drive circuit is designed. The circuit uses a single end flyback switching power supply as the front stage control, and the linear pressure control constant current source is used as the post level control. After converting the single ended flyback power supply, the DC voltage output can be obtained, which is used as the input of the post stage voltage controlled constant current source.

Because the input voltage of the constant current source is controlled by a high efficiency single flyback switching power supply, the pressure control constant current source can accurately control the LED and can

change the input voltage of the constant current source in a large range, so the efficiency and precision are guaranteed, and the power supply can be supplied by the city. At the same time, the two level control is not easy to damage the LED lamp.

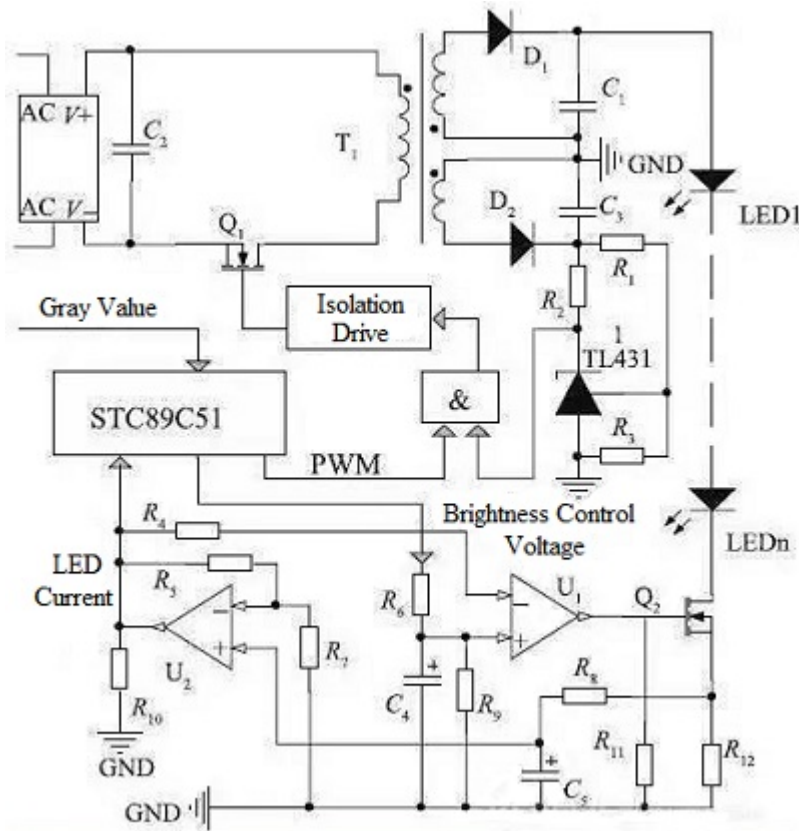

Figure 2. Novel Driver Circuit Design

The system circuit is shown in Figure 2. The transformer T1, the switch tube Q1, the diode D1 and the capacitor C1 constitute the single end flyback switching power supply, and the operational amplifiers U1, U2 and power transistor Q2 constitute the pressure controlled constant current source, and the MCU STC89C51 is the core control device. When the gray value changes, the microcontroller generates a corresponding brightness control voltage based on the gray value obtained. The brightness control voltage is added to the same phase input of U1. The reverse input terminal of U1 is the LED current signal obtained by U2, and R12 is the current detection resistor. The output voltage of the U1 is the control voltage of the MOS tube Q2, which is known by the concept of the operational amplifier's deficiency. The reverse input voltage of the U1 is equal to the voltage on its forward input, that is, the current on the R12 is controlled by the brightness control voltage, and does not change with the change of the load.

Singlechip produces a corresponding luminance control voltage according to the gray value it gets, and also produces a PWM signal. The PWM signal meets the TL431 signal to control the switch of the Q1. Then the MCU changes the duty ratio of the PWM signal according to the LED current signal obtained, and changes the output voltage of the switching power supply, that is to change the constant. The input voltage of the flow source reduces the voltage on the power tube Q2, so that it works in the adjustable resistance zone or near the adjustable resistance zone in the case of the constant output current, in order to improve the efficiency. TL431 is the three terminal adjustable shunt reference, where the existence of TL431 and its corresponding electric

phase is to limit the maximum output voltage of the switching power supply and further improve the security of the system.

When the light is relatively good, the MCU controls the output of the luminance control voltage according to the gray value obtained, so that the output current of the constant current source is relatively small, and the energy saving effect can be achieved. In Figure 2, the output voltage of the microcontroller is controlled by D/A to supply the constant current source. Figure 2 does not draw the D/A part.

VII Basic Suggestion for Designing LED Driver

The design of LED driver is not difficult, but we must have a good idea. As long as we do debugging before calculation, debugging and aging after debugging, we believe that anyone can do well in LED.

7.1 LED Current Size

As we all know, if LED ripple is too large, the life of LED will be affected and how big the impact will be, but there are no specific indicators at present.

7.2 Chip Fever

This is mainly aimed at the high voltage drive chip of the built-in power modulator, which reduces the power consumption of the chip, and does not introduce extra power consumption to do the heat dissipation.

7.3 Power Tube Fever

The power consumption of power tube is divided into two parts, switching loss and conduction loss. LED is an electric drive application, and the switch damage is much larger than the conduction loss. The switching loss is related to the CGD and CGS of the power pipe and the driving ability and working frequency of the chip, so to solve the heat of the power pipe can be solved from the following aspects:

- A. MOS power tube can not be selected based on the size of the conduction resistance. The smaller the internal resistance, the larger the capacitance of CGS and CGD.
- B. The rest is frequency and chip drive capability. Here we only talk about the influence of frequency. The frequency is directly proportional to the conduction loss. So when the power tube is heating, we should first consider whether the frequency selection is a bit high. When the frequency is reduced, in order to get the same load capacity, the peak current must be larger or the inductance becomes larger, which may lead to the inductor into the saturation area. If the inductance saturation current is large enough, the CCM (continuous current mode) can be changed into DCM (discontinuous current mode), which requires an increase of a load capacitance.

7.4 Frequency reduction of working frequency

Frequency reduction is mainly caused by two aspects. The ratio of input voltage to load voltage is small and system interference is large. For the former, be careful not to set the load voltage too high, though the load

voltage is high, the efficiency will be high.

For the latter, we can try the following aspects: A, the smallest current set the smallest point; B, wiring clean point, especially the key path of sense; C, the selection of the inductor or the inductance of the closed magnetic circuit; D, RC low pass filter, this effect is a little bad, C is not good consistency, deviation is a bit big, But it should be enough for lighting.

7.5 The Selection of Inductors or Transformers

As the high power light emitting diode operating voltage is only 3V, the full bridge rectifier turns the 220V AC into DC, the voltage drop on the full bridge is about 1.8V, and the power utilization efficiency of only one light emitting diode is only 60%. We must connect more than 3 light-emitting diodes together to make the total electricity utilization efficiency more than 80%.

According to the principle of three basic color synthesis white light, 3 1W high-power light emitting diodes with red, green and blue are connected in series, and the brightness of the LED equivalent to the white light of 3W can be obtained. At the same time, 6 kinds of color light can be combined to satisfy people's preference for color conversion.



VIII Conclusion

The LED driver circuit uses the switching power supply as the first level of control, the pressure control constant current source as the second level of control, combined with the advantages of the two, the efficiency and control precision are guaranteed, and can be directly supplied by the city electricity, two level drive, high safety, and can not easily damage the high price LED lamp. Experiments show that the efficiency of the system can reach more than 83%, and the power is the same as the single ended flyback switching power supply, so it is worth promoting.

Frequently Asked Questions about LED Driver Basics

1. What is an LED driver used for?

LED drivers are devices which regulate and supply the power used to 'drive' runs of LED strip lighting. Similar to traditional transformers, they transform mains voltage alternating current (240v AC) to a lower voltage.

2. Do I need a driver for LED lights?

Every LED light source requires a driver. ... Some LEDs already include an integrated driver within the bulb. LEDs designed for household use (bulbs with E26 / E27 or GU24 / GU10 bases and that run on 120V) typically already include a driver. However, low voltage LED light sources, such as some MR- bulbs (MR GU5).

3. What is the difference between a transformer and an LED driver?

What's difference between LED driver and LED transformer? A transformer is by convention a double wound device, just ac in, ac out. Drivers are more sophisticated than that and usually give a dc output using a switched-mode system, also they have current regulating and monitoring circuits in them.

4. Can a LED driver be used as a power supply?

Constant Voltage LED Drivers. Constant current and Constant voltage drivers are both viable options for a power supply for LED light sources, what differs is the way in which they deliver the power.

5. How many LEDs can a driver power?

If you have a driver with a wattage output of 60 watts, it should only operate LEDs that use a combined 48 watts ($60w \times 80\% = 48w$). How many lights can one driver power? Drivers are not limited by the number of LED lights they power. They are restricted by the total wattage of the LED lights they power.

6. How long does an LED driver last?

Namely, the life of the driving circuit expires prior to when the LED stops emitting light or has its brightness dropped. The typical nominal lifetime of these elements is often times less than 25,000 hours, while the lifetime of LED itself could be as long as 50,000-100,000 hours.

7. Do LED drivers get hot?

Heat is the enemy of electronics and this goes for LED drivers too. This doesn't mean that LED drivers cannot operate in hot environments, they can. ... The output capacity of a switch-mode power supply, including LED drivers reduces as the temperature increases.

8. How do I choose an LED driver?

Use an LED driver with at least the same value as your LED(s). The driver must have a higher output power than your LEDs require for extra safety. If the output is equivalent to the LED power requirements, it is running at full power. Running at full power may cause the driver to have a shorter life span.

9. How do I know if my LED drivers are bad?

LED drivers rectify higher voltage alternating current to low voltage. If you have a good LED and a bad operating LED driver your high bay LED Lights won't be functional for long. Most LED failures are not from the LED, but from the driver. Usually the circuits burn out and fail.

10. How does an LED driver circuit work?

In electronics, an LED circuit or LED driver is an electrical circuit used to power a light-emitting diode (LED). ... The voltage drop across an LED is approximately constant over a wide range of operating current; therefore, a small increase in applied voltage greatly increases the current.

Book Recommendation

- Electronic Drivers for LED Devices, Arrays or Systems (NEMA SSL 1-2010)
--The Association of Electrical Equipment and Medical Imaging Manufacturers (Author)
- LED Applied Technology Series Books: LED driver power supply design of 100 cases (Chinese)
Paperback – 1991
--ZHOU ZHI MIN DENG (Author)
- Low Cost Low Voltage Low Power Integrated LED Driver Paperback – July 14, 2016

It is quite clear that economic growth is closely linked to energy availability. Energy availability can be approached by two ways; the first way is to build more power plants to cover the increased demand. The second way is to reduce the power consumption. LED lighting has many advantages like high reliability, low maintenance cost, dimming in addition to the main advantage of energy saving and strong expected performance enhancement. On the other hand, the disadvantages are mainly due to the initial cost of changing the lighting systems in addition to the need of a special power electronics circuitry to drive them for regulated intensity and brightness. The project goal is replace the halogen bulbs (50W) to integrated led lamp (10W). LEDs have many advantages when compared with other light sources such as incandescent or fluorescent lamps. The most significant advantages are fast turn-on, lower heat generation, lower power consumption and higher operating life. LEDs need to be driven properly to ensure optimal performance and long life. The driver must be cost effective, which is not usually achieved with discrete components but can be realized with integrated solutions.

--Aya Gebreel Ahmed (Author), Mahmoud Nassary Abd Al-Fattah (Author), Aya Bakr Abd Al-Wahab (Author)

Relevant information about "LED Driver Basics and Its Circuit Design"

About the article "LED Driver Basics and Its Circuit Design", If you have better ideas, don't hesitate to write your thoughts in the following comment area. You also can find more articles about electronic semiconductor through Google search engine, or refer to the following related articles.

- [Contemporary LED Lighting Technology and Application in Our Daily Life](#)
- [LED lighting circuit protection](#)
- [Why do LED lights Generate Heat and the Lighting Calculation Formula](#)



<https://www.apogeeweb.net>
